



ADDENDUM 2

PROJECT NAME: Pickwell Park Improvements

DATE: 01/13/2025

PROJECT NO: 23-04014

This addendum is separated into sections for convenience; however, all respondents, bidders, contractors, subcontractors, material men, and other parties must be responsible for reading the entire addendum. The failure to list an item or items in all affected sections of this addendum does not relieve any party affected from performing as per instructions, providing that the information is set forth one time any place in this addendum. These documents will be attached to and will become part of the Contract Documents for this project. The respondent/bidder is required to acknowledge the receipt of this addendum.

GENERAL:

1. The following changes and/or additions to the Contract Documents, via this addendum, must apply to proposals made for and to the execution of the various parts of the work affected thereby.
2. Careful note of the Addendum must be taken by all interested parties and all trades affected must be fully advised in their performance of the work involved.
3. This Addendum is hereby made part of the project requirements and contract documents for the above reference project. Ensure to acknowledge this Addendum in CivCast when downloading this Addendum. Acknowledgement of this Addendum is a requirement in order to submit bid in CivCast. This addendum consists of the items and their associated attachments as listed below:

A. CHANGES TO PLANS:

Base Bid A

1. Title Sheet
 - Remove the fifth bullet of the Base Bid B description, "installation of concrete pads for picnic table seating areas, one area to be accessible as shown per plan." There are no picnic table associated with Base Bid B and have been removed from plans.

Base Bid B

2. L0.00
 - Change notes – contractor to reference base bid A for light fixtures and water fountain
3. L1.01
 - provide spot elevations on sport court and slope percentage
 - update symbol legend
 - show location of proposed control/ expansion joints
 - update material schedule add – J5, G1, G2 and removed items not being used

- 4. L2.01
 - Provide hatch symbol and label to detail 1
 - Add notes to detail 2 & 4
- 5. L2.02
 - Add note to detail 1
 - Removed net and fence details covered and shown on structural sheets
- 6. S1.04
 - revise location of the intersecting grade beams at the basketball goal post. The plan note has been clarified for the contractor to coordinate the final goal post.
- 7. S2.01
 - Revise cushion court surface note in details 3 and 4 as sport court will not have a cushion layer.

B. CHANGES TO SPECIFICATIONS:

- 1. Add SportMaster Pickleball Court Resurfacing Specifications – on concrete to project manual
- 2. Update Project manual sheet index
- 3. Add specifications to the shade structure and notes to the scope summary clarifying that the shade structure item is to be turn-key and include engineering and permitting for the structure.

SIGNED AND SEALED BY CONSULTANT (Engineer/Architect of Record)

By signing and sealing this addendum, the Engineer/Architect of Record acknowledges that the sign/seal is only for changes/clarifications to the items associated with the Engineer's/Architect's work referenced in this addendum.



1/13/25

Darcy Nuffer

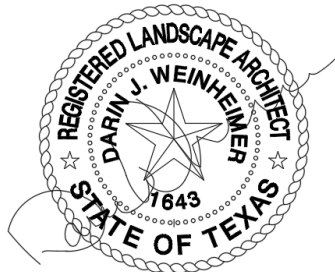

1/13/25

David Rios

David Rios
Procurement Manager
Finance Department - Procurement Division

END OF ADDENDUM NO. 2

DOCUMENT SEALS PAGE

Issued for:

100% Construction Documents



12/192024

WGI

4700 Mueller Boulevard, Suite 300
Austin, TX 78723

LANDSCAPE ARCHITECTURAL RESPONSIBILITY

SPECIFICATION SECTIONS:

- 507 CHAIN LINK WIRE FENCE
- 515 TOPSOIL
- 516 SODDING
- 520 HYDROMULCHING
- 804 NEW TREE & SHRUB PLANTING AND MAINTENANCE
- 9000 PLANTING
- 133123 PRE-ENGINEERED SHADE STRUCTURES



CIVIL'S RESPONSIBILITY

SPECIFICATION SECTIONS:

- 100 MOBILIZATION
- 103 REMOVE CONCRETE
- 300 CONCRETE
- 301 REINFORCING STEEL
- 400 EXCAVATION, TRENCHING AND BACKFILLING
- 502 CONCRETE SIDEWALKS
- 533 CLEANING AND REMOVAL OF PAVEMENT MARKINGS AND MARKERS
- 535 HOT APPLIED THERMOPLASTIC PAVEMENT MARKINGS
- 556 CAST IN PLACE DETECTABLE WARNING SURFACE TILES

MEP'S RESPONSIBILITY

SPECIFICATION SECTIONS:

- 260001 - BASIC REQUIREMENTS FOR ELECTRICAL
- 260519 - LOW-VOLTAGE ELECTRICAL POWER CONDUCTORS AND CABLES

23-04014 Pickwell Park Specifications
December 19, 2024

SECTION 13 31 23
PRE-ENGINEERED SHADE STRUCTURES

PART 1 – GENERAL

1.1 RELATED DOCUMENTS

- A. Drawings and general provisions of the Contract, including General Conditions and Division 1 Specification Sections apply to this section.

1.2 SUMMARY

- A. The shade structure contractor shall be responsible for the design, engineering, fabrication, supply, and installation (including foundations) of the work specified herein. Scope is to include site specific permit submittal and approval by City of San Antonio, including close out. The intent of this specification is to have only one single contractor be responsible for all the above functions.

1.3 REFERENCES

- A. Shade Structures must comply with the latest revision of applicable codes and regulations including IBC 2021.
- B. American Society for Testing Materials (ASTM)
- C. American Welding Society: Structural Welding Code AWS D1.1: Symbols for Welding and Nondestructive Testing AWS 2.3.
- D. International Accreditation Services (IAS)
- E. American Institute of Steel Construction (AISC): Specifications for the design, fabrication, and erection of structural steel.

1.4 SUBMITTALS

- A. Provide proof of installed reference sites with six structures for similar scope of project and installation that are engineered to IBC 2021 Specifications.
- B. Provide proof of a minimum of 3 separate permitted shade structure projects of similar scope with the City of San Antonio, including electrical integration review, special inspections and permit close-out.
- C. Provide a minimum of 13 fabric samples to demonstrate fabric color range and powder color selections.
- D. Provide proof of all quality assurance items including:
 - 1. A list of at least three reference projects of similar type structures that have been installed in the last 10 years as described below in 2.1 General, Scope.
 - 2. Proof of general liability, professional liability, and umbrella insurance as per Article XI of 081 General Conditions for Construction Contracts for the City of San Antonio.
 - 3. Proof of a minimum of aggregate bonding capacity as per Article XI of 081 General Conditions for Construction Contracts for the City of San Antonio.
 - 4. Proof of IAS Certification per Section 1.5 F.
 - 5. Proof of current status as an ISNetwork Member Contractor.
 - 6. Proof of a Corporate Safety Program along with an Injury & Illness Prevention Program.
 - 7. Proof of Corporate Quality Control Manual as per Section 1.5 H
 - 8. Proof of Maintenance Program and 3 reference projects where maintenance has been provided, where necessary, during the duration of the warranty.

1.5. QUALITY ASSURANCE

Fabrication and erection are limited to firms with proven experience in design and construction of fabric shade structures and such firms shall meet the following minimum requirements. No substitutions shall be allowed for the following:

- A. A single shade contractor shall design, engineer, manufacture, and erect the fabric shade structures. Contractor shall provide permit submittal and obtain permits through the local city agencies, including special inspections, payment & performance bonds, close out of permitted project with local agency and all at NET 30 terms.
- B. All bidders shall have at least 12 years' experience in the design, engineering, manufacturing, and installation of shade structures.
- C. All bidders shall engineer to IBC 2021 requirements with similar scope.
- D. All bidders shall be able to provide proof of \$3,000,000 general/public liability insurance, \$1,000,000 professional liability (PL) insurance, \$1,000,000 business automobile liability and an additional \$5,000,000 umbrella/excess liability insurance per Article XI of 081 General Conditions for Construction Contracts for the City of San Antonio.
- E. All bidders shall be licensed and bonded with a minimum bonding capacity per Article XI of 081 General Conditions for Construction Contracts for the City of San Antonio.
- F. Steel manufacturer shall be accredited by IAS (International Accreditation Service) for Structural Steel Fabrication under UBC 97 & 2000 Section 1701.7 and IBC 2021 Section 1704.2.2.
- G. Proof of current status as an ISNetworld Member Contractor.
- H. The shade contractor shall have a Corporate Quality Control program and manual describing their complete quality assurance program.
- I. All bidders must have an in-house warranty & service department and local office to assist in repairs and service calls within 48 hours.

1.7 WARRANTY

- A. The successful bidder shall provide a 12-month warranty on all labor and materials.
- B. A supplemental warranty from the manufacturer shall be provided for a period of 10 years on fabric and 10 years on the structural integrity of the steel from the date of substantial completion.
- C. The warranty shall not deprive the Owner of other rights under the provisions of the Contract Documents and will be in addition to and run concurrent with other warranties made by the Contractor under requirements of the Contract Documents.

PART 2 – PRODUCTS

2.1 GENERAL: BASE BID

Scope:

Provide (1) one 56' x 90' 6 Post Super Span Shade Structure, Model # 604_5690-16 measuring 56' x 90' with 16' entry height. Columns shall measure a minimum of HSS 10.00 x 10.00 x 0.375 and upper framing extensions shall measure a minimum HSS 8.00 x 6.00 x 0.250. The framing shall support two fabric tops with kedar rail. No exceptions. Steel columns and upper frame must be designed and built to accommodate integrated wiring and lighting fixtures. Appropriate openings (with covers) shall be designed to allow wiring to be pulled through the hollow inside of the structure's steel, resulting in electrical power to be available for light fixtures, which will be attached to the steel's upper frame. Wiring and lighting fixtures will be installed by others after the erection of the steel

structure. Once wiring is placed, fitted covers in the same steel texture and color shall be placed over the openings to create a sealed connection and polished look

A. Basis of Design:

The structures are to be provided by CAPITAL SHADE, manufactured by Shade Structures, Inc. dba USA SHADE & Fabric Structures, or approved equivalent and include the structural steel frame, fabric roof, steel cables, all fasteners, and installation. Scope shall include the design, engineering, fabrication, supply, and installation (including foundations) of the work specified herein. Scope is to include site specific permit submittal, close out.

Contact:

CAPITAL SHADE, LLC
15511 Hwy 71 W, Suite 110-128
Austin, Texas 78738
Contact Name: Michelle Botha – Phone: 512-937-6430
michelle@capitalshade.com

B. To qualify as an approved equivalent, please submit product documentation, fabric samples and all quality assurance criteria as per Section 1.4 & 1.5 at least 10 days prior to bid date. Approved equals will be issued per addendum prior to bid date.

C. The shade structure shall conform to the current adopted version of the International Building Code 2021 and local agency additions and amendments.

D. All shade structures are engineered and designed to meet a minimum of 115 mph wind load, Exposure C, live load of 5 lbs/sf² and a 5 lbs/sft² snow load. When ASD Steel Design Method is used based on IBC 2021 Section 1605.3.1, the Dead + 0.75 of Live + 0.75 of Wind Load cases must be combined. NO EXCEPTIONS.

E. Steel:

1. All steel members of the shade structure shall be designed in strict accordance with the requirements of the "American Institute of Steel Construction" (AISC) Specifications and the "American Iron and Steel Institute" (AISI) Specifications for Cold Formed Members and manufactured in a IAS (International Accreditation Service) accredited facility for Structural Steel Fabrication as per IBC 2021 Section 1704.2.2.
2. All connections shall have a maximum internal sleeving tolerance of .0625 inches using high tensile strength steel sections with a minimum sleeve length of 6 inches.
3. All non-hollow structural steel members shall comply with ASTM A-36. All hollow structural steel members shall be cold formed, high strength steel and comply with ASTM A-500, Grade C. All steel plates shall comply with ASTM A-572, Grade 50. All galvanized steel tubing shall be triple coated for rust protection using an in-line electro-plating coat process. All galvanized steel tubing shall be internally coated with zinc and organic coatings to prevent corrosion.
4. All columns shall be hot-dip galvanized for additional corrosion prevention due to close proximity to pool and irrigated areas.

F. Welding:

1. All shop-welded connections of the shade structure shall be designed and performed in strict accordance with the requirements of the "American Welding Society" (AWS) Specifications. Structural welds shall be made in compliance with the requirements of the

“Prequalified” welded joints where applicable and by certified welders. No onsite or field welding shall be permitted.

2. All full penetration welds shall be continuously inspected by an independent inspection agency and shall be tested to the requirement of IBC 2021 and local agency additions and amendments.
- G. Powder Coating:
1. Galvanized steel tubing preparation prior to powder coating shall be executed in accordance to solvent cleaning SSPC-SP1. Solvent such as water, mineral spirits, xylol, toluol, which are to be used to remove foreign matter from the surface. A mechanical method prior to solvent cleaning prior to surface preparation shall be executed according to Power Tool Cleaning SSPC-SP3 and utilizing wire brushed abrasive wheels and needle gun, etc.
 2. Carbon structural steel tubing preparation prior to powder coating shall be executed in accordance to commercial blast cleaning SSPC-SP6 or NACE #3. A commercial blast- cleaned surface, when viewed without magnification, shall be free of all visible oil, grease, dirt, mill scale, rust, coating, oxides, corrosion, products and other foreign material.
 3. Powder coating shall be sufficiently applied, with a minimum three mils thickness and cured at the recommended temperature to provide proper adhesion and stability to meet salt spray and adhesion tests as defined by the American Society of Testing Materials.
 4. Powder used in the powder coat process shall have the following characteristics:
 - a. Specific Gravity: 1.77 +/- 0.05 g/cm³
 - b. Coverage at 1.0 mils: 109sq.ft/lb/mil
 - c. Storage: 80° F
 - d. Interpron 800 HR is a series of high durability TGIC powder coatings designed for exterior exposure. Tested against the most severe specifications, Interpron 800 HR gives significantly improved gloss retention and resistance to color change.
 - e. Rust Protection Powder Under Coat Primer will be required on all structures in close proximity to water or chemicals. POWDURA® Epoxy Powder Coating Z.R. Primer shall be applied in accordance with the manufacturers’ specifications. Primer should be fused only and then top coated with the selected powder coat to ensure proper intercoat adhesion.
- H. Tension Cable: Steel cable is determined based on calculated engineering loads.
1. For light and medium loads, ¼” (nominal) galvanized 7 x 19 strand cable to be used.
 2. For heavy loads, 3/8” (nominal) galvanized 7 x 19 cable to be used.
- I. Fabric Roof Systems
1. UV shade fabric is made of UV stabilized Shadesure® cloth as manufactured by MultiKnit Ltd and made of a UV stabilized high-density polyethylene mesh. Mesh shall be raschel knitted with monofilament and tape yarn filler to ensure that material will not unravel if cut. Panels to be 10ft. wide.
 2. Fabric Properties:
 - a. Life Expectancy: A minimum of 8 years continuous exposure to the sun
 - b. Fading: Minimum fading after 5 years (3 years for red)
 - c. Fabric Mass: 2.43-2.58 oz/sqft (190-200g/sm)
 - d. Fabric Width: 9.8425 (3m)
 - e. Roll Length: 164.04 (50m)
 - f. Roll Dimensions: 62.99”x16.5354” (160 cm x 42 cm)
 - g. Roll Weight: +/- 66 lbs (+/-30 kg)
 - h. Minimum Temperature: -13°F (-25° C)
 - i. Maximum Temperature: +176°F (80° C)

3. Stitching & Thread:
 - a. All sewing threads are to be double stitched.
 - b. Thread shall be GORE Tenara Sewing Thread manufactured from 100% expanded PTFE (Teflon); mildew resistant exterior approved thread. Thread shall hold a 10 (ten) year warranty. Thread shall meet or exceed the following:
 - i. Flexible temperature range
 - ii. Very low shrinkage factor
 - iii. Extremely high strength, durable in outdoor climates
 - iv. Resists flex and abrasion of fabric
 - v. Unaffected by cleaning agents; acid rain, mildew, salt water and rot resistant, unaffected by most industrial pollutants
 - vi. Treated for prolonged exposure to the sun

2.2 SHIPPING AND HANDLING

- A. All steel surfaces touched by tie down straps are to be padded before final clinching. This can be accomplished by using carpet pads or factory manufactured padding.
- B. All dunnage must be padded before painted products are set in place. Smaller and loose pieces must be padded and totally separate from paint padding.
- C. Unloading: Lift forks to be covered with padding. All dunnage must be padded vertically and horizontally to prevent damage to painted surfaces. When unloading, take care to prevent tools and other hard surface items from making contact.

PART 3 – EXECUTION

3.1 INSTALLATION

- A. Installation of shade structures shall be performed by manufacturer or manufacturer-approved contractor, which shall be bonded and holding a current contractor’s license with the State of Texas Contractors State License Board. All installation personnel must have and show proof of experience in the erection of tensioned fabric structures.
- B. The contractor installing the structure shall comply with manufactures instructions for assembly, installation, and erection per approved drawings.
- C. Concrete:
 1. Unless noted otherwise for footing and piers by General Contractor’s Engineer, concrete specification for footings, piers, slabs, curbs and walkways shall meet a minimum 2,500 psi at 28-day strength.
 2. Concrete work is executed in strict accordance with the latest American Concrete Institute Building Code (ACI 318-99).
 3. Slump 4” maximum.
 4. Whenever daily ambient temperatures are below 80 degrees Fahrenheit, the contractor may have mix accelerators and hot water added at the batch plant.
 - a. Temperature range between 75-80 degrees, 1% accelerator High Early (non-calcium)
 - b. Temperature range between 70-75 degrees, 2% accelerator High Early (non-calcium)
 - c. Temperature range below 70 degrees, 3% accelerator High Early (non-calcium)
 5. The contractor shall not pour any concrete when daily ambient temperature is below 55 degrees Fahrenheit.

Temperature Range	% Accelerator	Type Accelerator
75-80 degrees	1%	High Early (non-calcium)
70-75 degrees	2%	High Early (non-calcium)
Below 70 degrees	3%	High Early (non-calcium)

D. Foundations:

1. All Anchor Bolts set in new concrete shall be ASTM F-1554 GR 55
2. All Anchor Bolts shall be Hot Dipped Galvanized
3. Pier Footings:
Structure 1 - Minimum footing size shall be 36" diameter x 13' depth and placed in accordance with/ and conform to manufacturers engineered specifications and drawings.

END OF SECTION 13 31 23

Date:	Revisions/Submissions
10/29/24	Issue for Bid
01/10/25	Addendum 02

CITY OF SAN ANTONIO
TRANSPORTATION AND CAPITAL IMPROVEMENTS
VERTICAL PROJECT MANAGEMENT DIVISION
MUNICIPAL PLAZA BUILDING 114 W. COMMERCE
P.O. BOX 839966 SAN ANTONIO, TX 78283-3966
TEL. (210) 207-2879 FAX (210) 207-2197

DISTRICT 3: PICKWELL
6911 PICKWELL DR.
SAN ANTONIO, TEXAS 78223

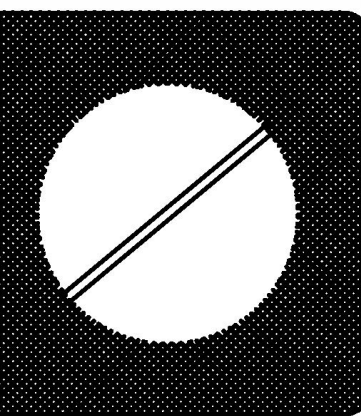

Drawn By:
KR
Date:
11/15/24
Project No.:
CSA-301
Sheet Name:
DEMO PLAN
Sheet Number:
L0.00

PLANT LEGEND	
	EXISTING TREE TO REMAIN
	TREE PROTECTION FENCE
	AREA OF DEMOLITION HATCH

- GENERAL TREE NOTES**
- 1) ALL THE TREE WITH A DIAMETER GREATER THAN 3 INCHES AFFECTED BY CONSTRUCTION SHALL HAVE THE LIMBS AND ROOTS TRIMMED AND PRUNED.
 - 2) ALL TREES SHALL REMAIN UNLESS NOTED ON THE PLANS.
 - 3) NO SITE PREPARATION WORK SHALL BEGIN IN AREAS WHERE TREE PRESERVATION AND TREATMENT MEASURES HAVE NOT BEEN COMPLETED AND APPROVED
 - 4) TREE PROTECTION FENCING SHALL BE REQUIRED. TREE PROTECTION FENCING SHALL BE INSTALLED, MAINTAINED AND REPAIRED BY THE CONTRACTOR DURING SITE CONSTRUCTION.
 - 5) THE CONTRACTOR SHALL AVOID CUTTING ROOTS LARGER THAN THREE INCHES IN DIAMETER WHEN EXCAVATING NEAR EXISTING TREE. EXCAVATION IN THE VICINITY OF TREES SHALL PROCEED WITH CAUTION. THE CONTRACTOR SHALL CONTACT CITY INSPECTOR.
 - 6) THE ROOT PROTECTION ZONE IS THAT AREA SURROUNDING A TREE AS MEASURED BY A RADIUS FROM THE TREE TRUNK IN WHICH NO EQUIPMENT VEHICLES OR MATERIAL MAY OPERATE OR BE STORE. THE REQUIRED RADIUS LENGTH IS 1 FOOT PER DIAMETER INCH OF THE TREE.
 - 7) ACCESS TO FENCED AREA WILL BE PERMITTED ONLY WITH THE APPROVAL OF THE LANDSCAPE ARCHITECT OR CITY INSPECTOR.
 - 8) GRADING, IF REQUIRED, SHALL BE LIMITED TO A 3 INCH CUT OR FILL WITHIN THE FENCED ROOT ZONES AREAS.
 - 9) TREE, SHRUBS OR BUSHES TO BE CLEARED FROM PROTECTED ROOT ZONE AREA SHALL BE REMOVED BY HAND AS DIRECTED BY THE PROJECT LANDSCAPE ARCHITECT OR CITY INSPECTOR
 - 11) ANY TREE REMOVAL SHALL BE APPROVED BY THE CITY OF SAN ANTONIO PRIOR TO REMOVAL

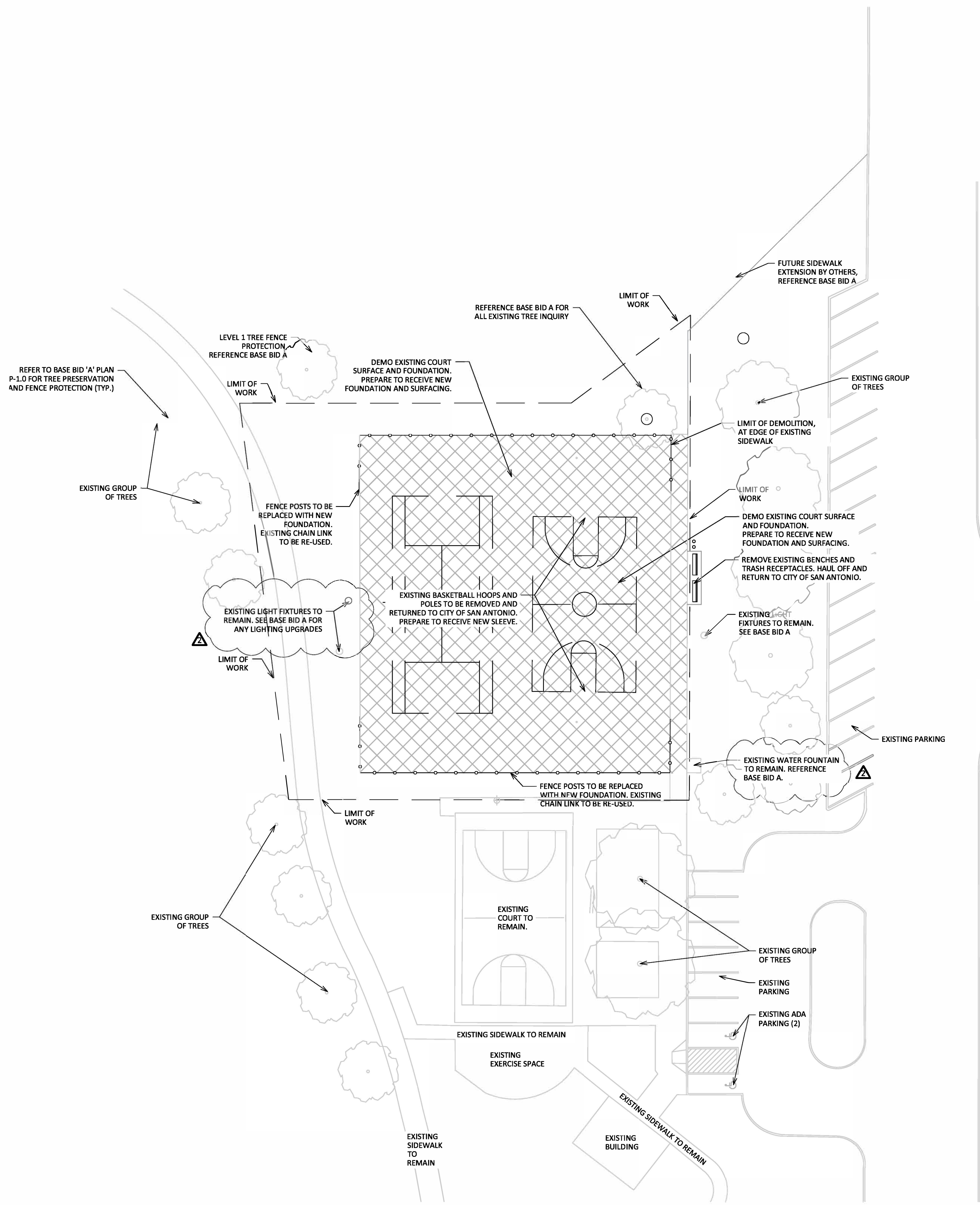

SCALE 1" = 20' - 0"
10 0 20 40

Date:	Revisions/Submissions
10/29/24	Issue for Bid
01/10/25	Addendum 02

CITY OF SAN ANTONIO
TRANSPORTATION AND CAPITAL IMPROVEMENTS
VERTICAL PROJECT MANAGEMENT DIVISION
MUNICIPAL PLAZA BUILDING 114 W. COMMERCE
P.O. BOX 839866 SAN ANTONIO, TX 78283-3966
TEL. (210) 207-2879 FAX (210) 207-2197

DISTRICT 3: PICKWELL
6911 PICKWELL DR.
SAN ANTONIO, TEXAS 78223

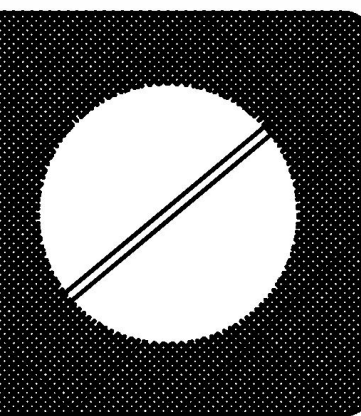

Drawn By:
KR
Date:
11/15/24
Project No.:
CSA-301
Sheet Name:
CONSTRUCTION DETAILS
Sheet Number:
L2.01

NOTE: PICKLEBALL AND BASKETBALL COURT STRIPING TO BE 2 INCHES WIDE WITH DIMENSIONS OF THE COURT BEING TAKEN FROM THE OUTER EDGE

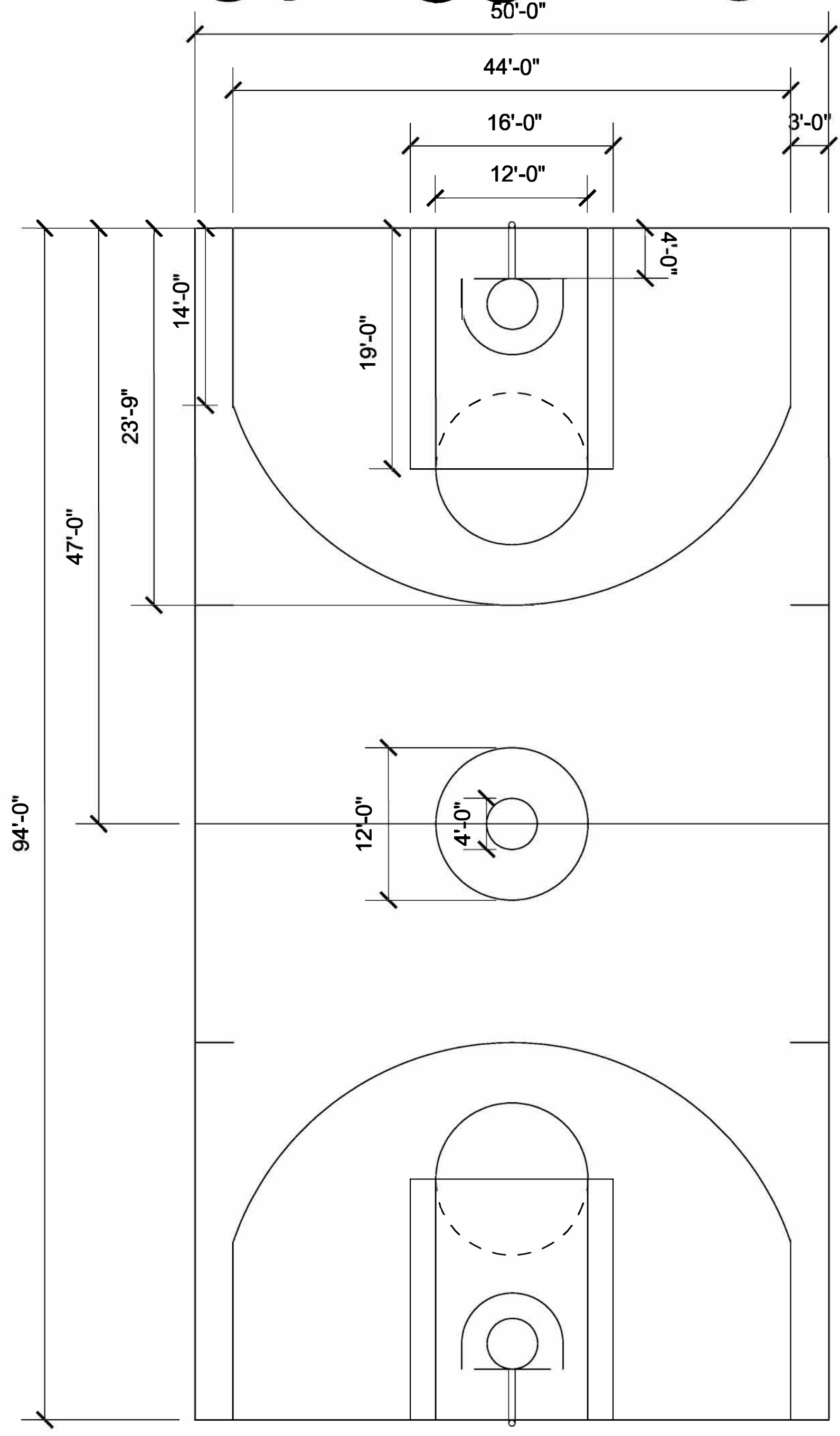

4 BASKETBALL COURT LAYOUT
N.T.S. PLAN

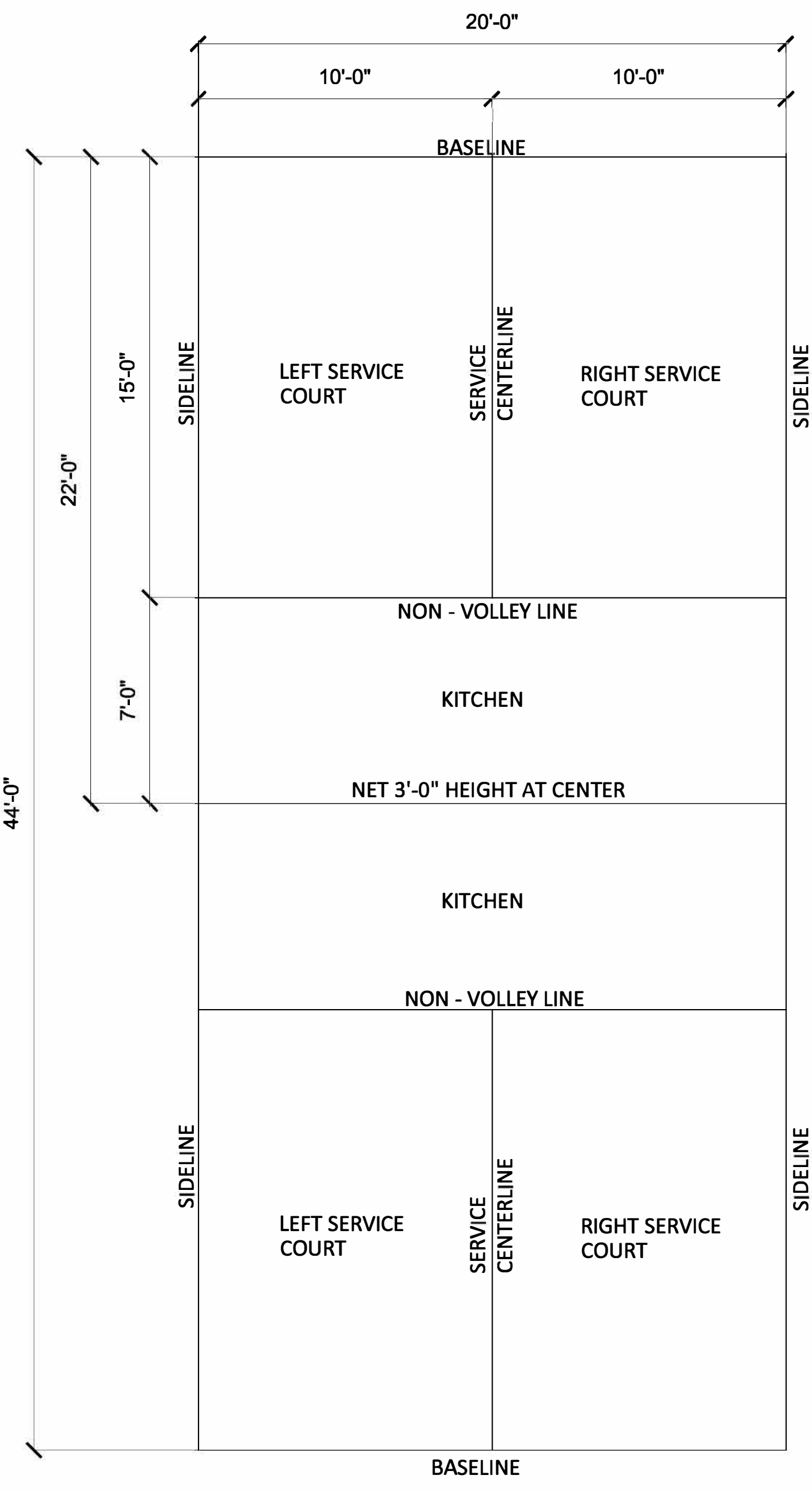

3 PICKLEBALL COURT LAYOUT
N.T.S. PLAN

NOTE: AWARDED CONTRACTOR TO REQUEST SIGN IMAGES FROM LANDSCAPE ARCHITECT



2 PICKLEBALL ALLUMINUM PLAY SIGNAGE
N.T.S.

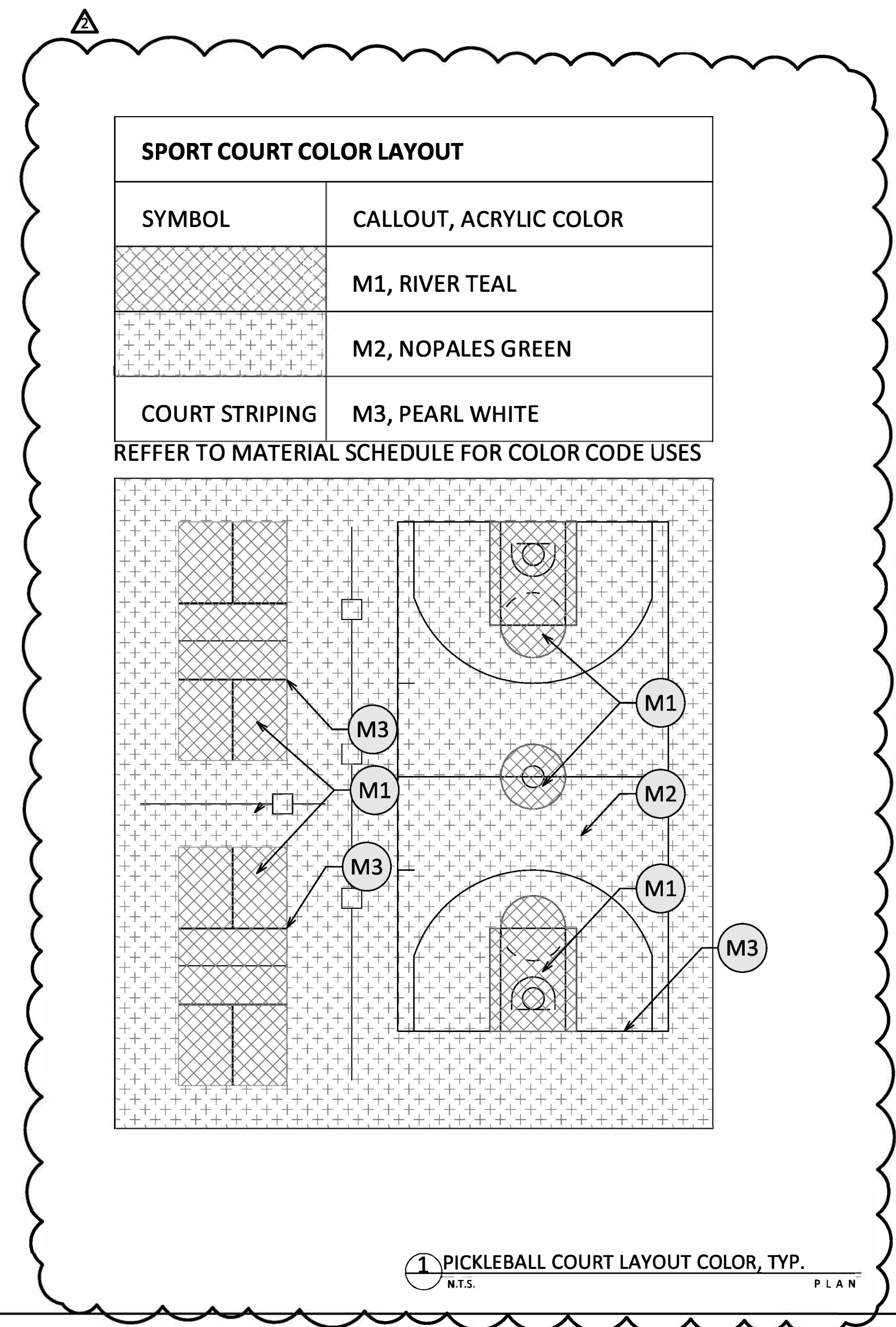

1 PICKLEBALL COURT LAYOUT COLOR, TYP.
N.T.S. PLAN

SPORT COURT COLOR LAYOUT

SYMBOL	CALLOUT, ACRYLIC COLOR
	M1, RIVER TEAL
	M2, NOPALES GREEN
	M3, PEARL WHITE

REFER TO MATERIAL SCHEDULE FOR COLOR CODE USES

Date:	Revisions/Submissions
10/29/24	Issue for Bid
01/10/25	Addendum 02

CITY OF SAN ANTONIO
TRANSPORTATION AND CAPITAL IMPROVEMENTS
 VERTICAL PROJECT MANAGEMENT DIVISION
 MUNICIPAL PLAZA BUILDING 114 W. COMMERCE
 P.O. BOX 839966 SAN ANTONIO, TX 78283-3966
 TEL. (210) 207-2879 FAX (210) 207-2197

DISTRICT 3: PICKWELL
6911 PICKWELL DR.
SAN ANTONIO, TEXAS 78223

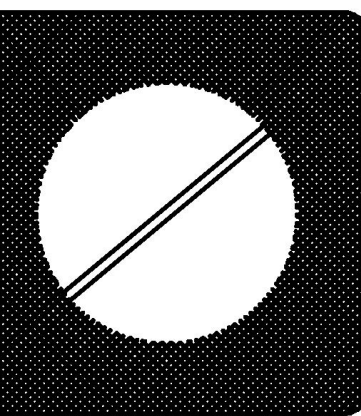

Drawn By:
 KR
Date:
 11/15/24
Project No.:
 CSA-301
Sheet Name:
 CONSTRUCTION DETAILS
Sheet Number:
 L2.02

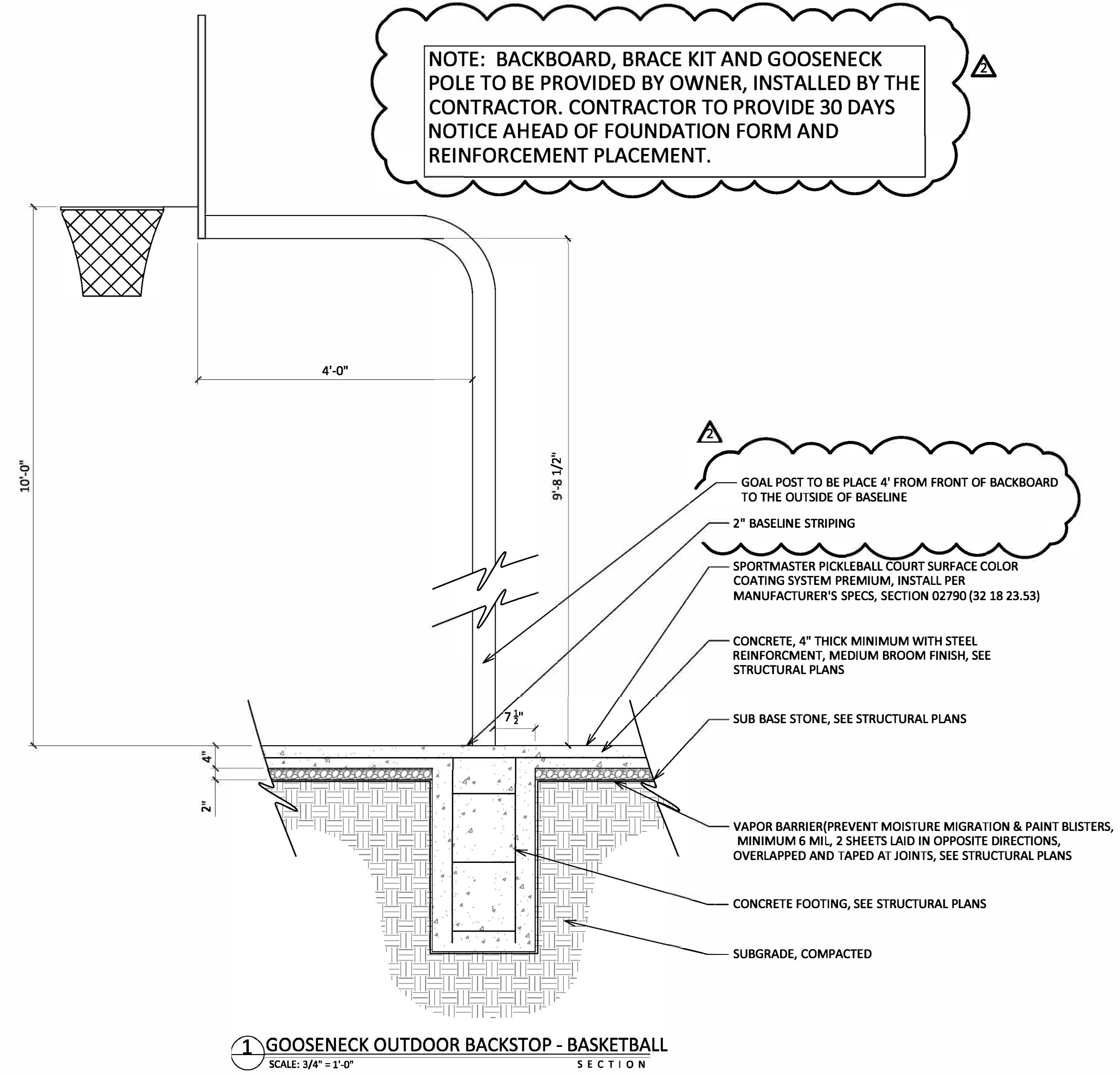
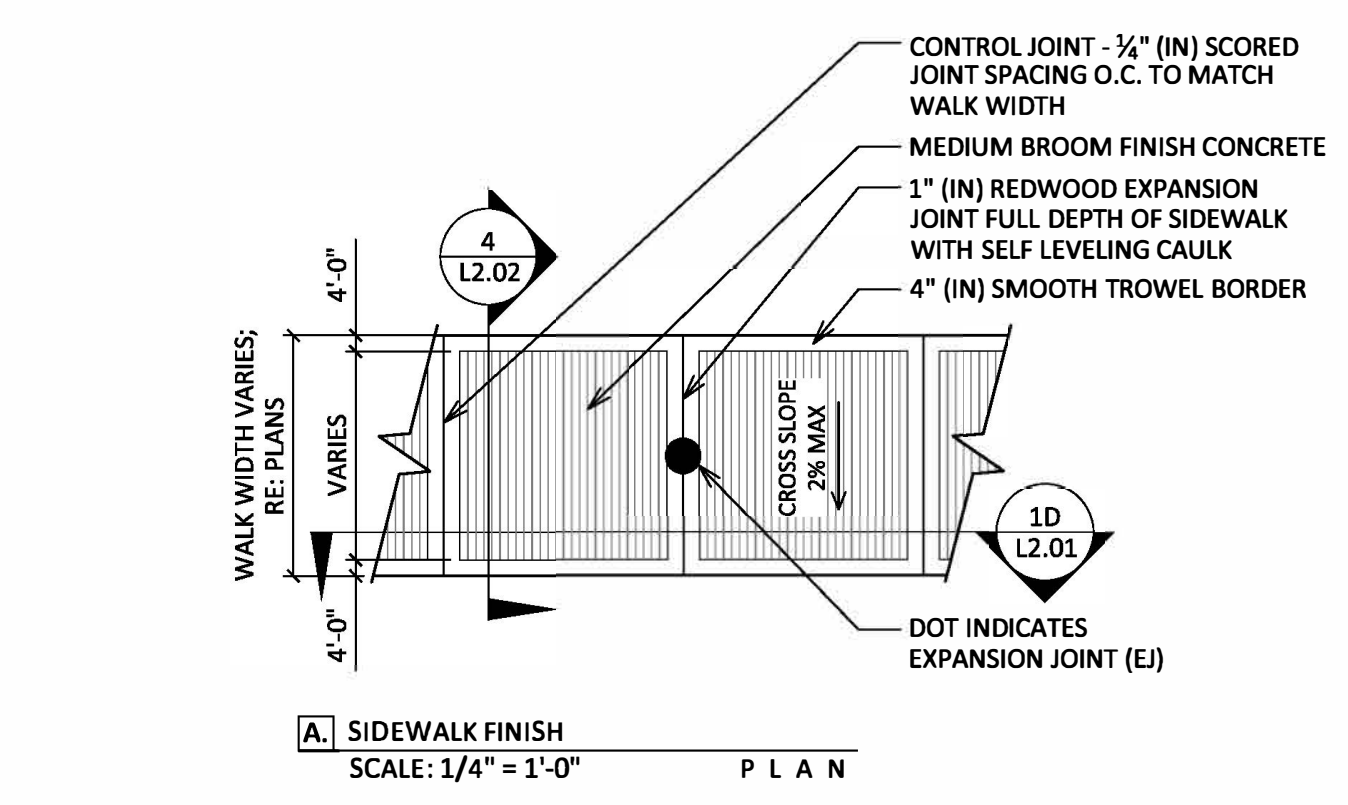
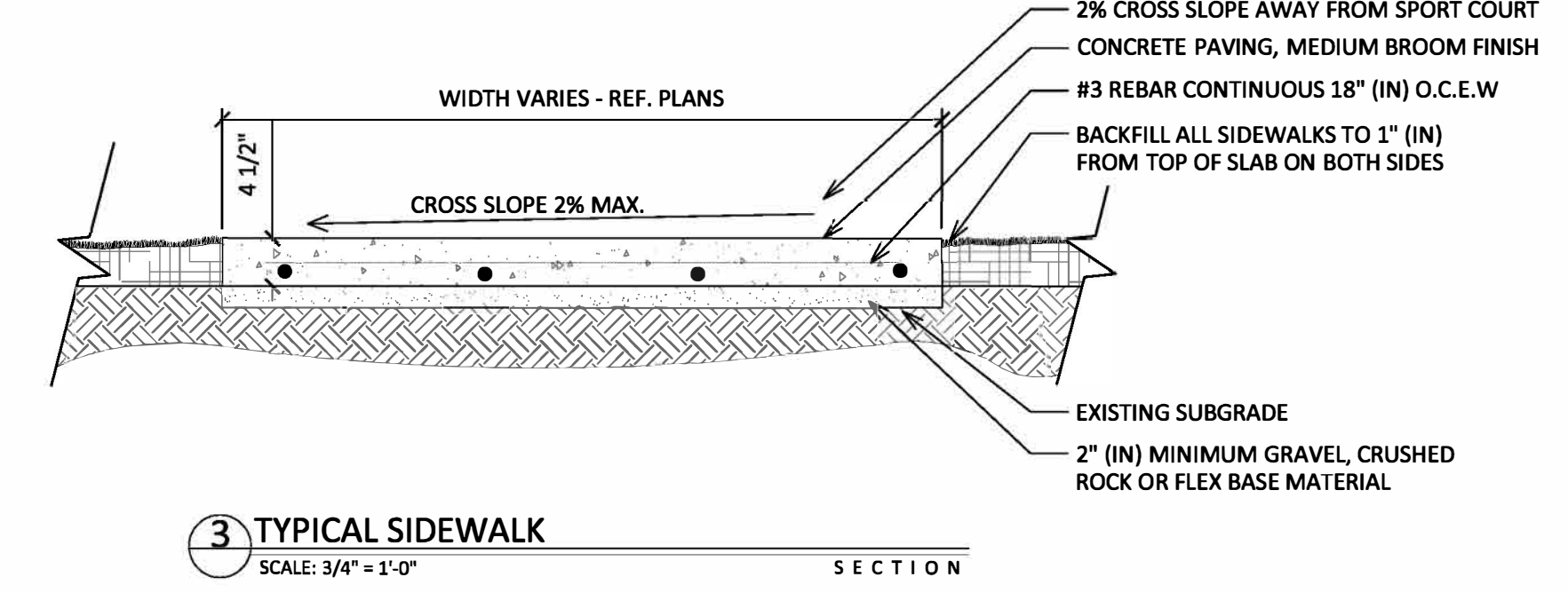
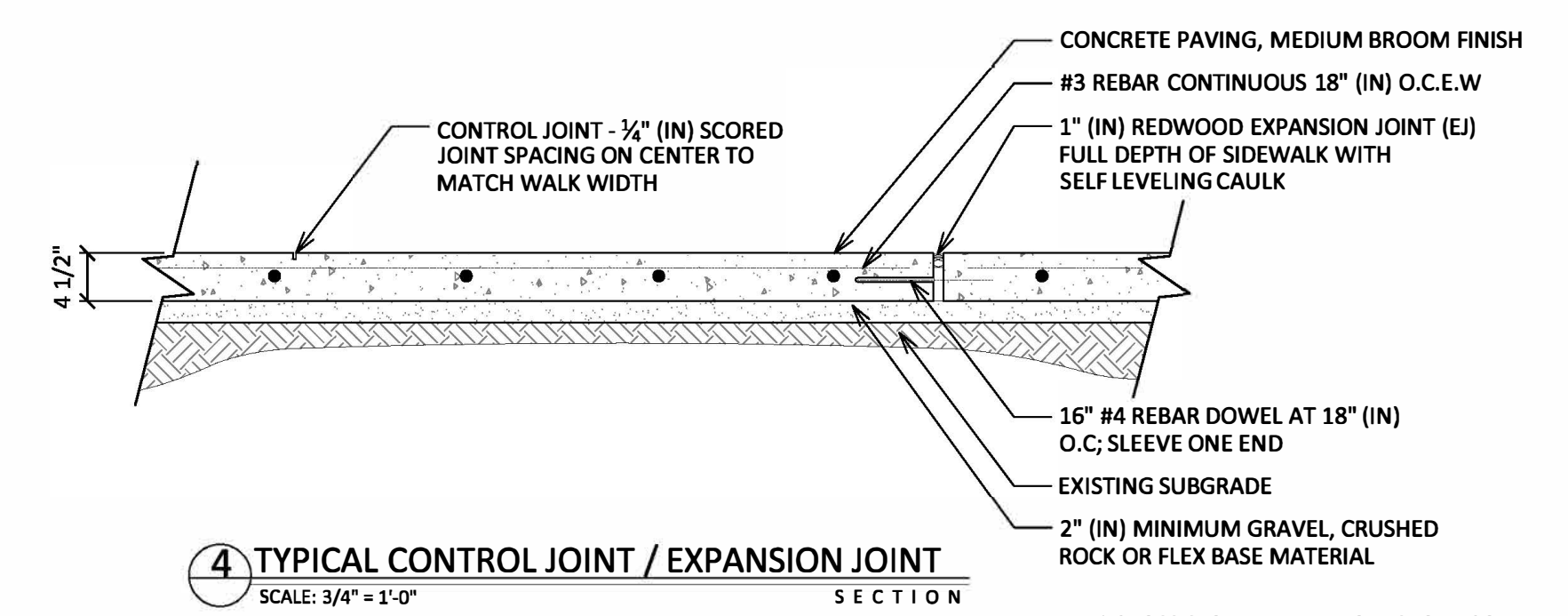

NOTE: BACKBOARD, BRACE KIT AND GOOSENECK POLE TO BE PROVIDED BY OWNER, INSTALLED BY THE CONTRACTOR. CONTRACTOR TO PROVIDE 30 DAYS NOTICE AHEAD OF FOUNDATION FORM AND REINFORCEMENT PLACEMENT.

12/15/23	Issue for DD
08/08/24	Issue for CD
08/22/24	Issue for Bid
09/12/24	Issue for Owner Review
01/10/25	Addendum 2

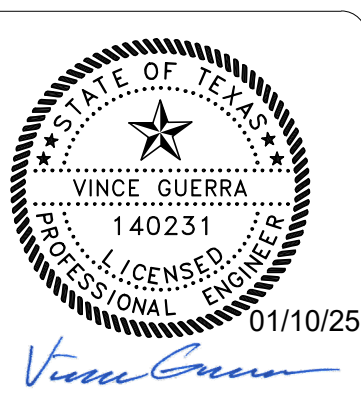

Drawn By:
VG

Date:
09/12/2024

Project No.:
23-04013

Sheet Name:
FOUNDATION PLAN - PICKWELL PARK

Sheet Number:
S1.04

- PLAN NOTES:**
1. FINISH FLOOR ELEVATION = 100'-0", UNLESS NOTED OTHERWISE.
 2. TOP OF CONCRETE ELEVATION (TOC EL.) = FINISH FLOOR, UNLESS RECESSED TO RECEIVE FLOORING MATERIALS.
 3. REFER TO THE LANDSCAPE ARCHITECTURAL DRAWINGS FOR EXACT LOCATIONS OF FLOOR RECESSES, DROPS AND SLOPES NOT DIMENSIONED ON PLAN.
 4. TYPICAL CONCRETE SLAB THICKNESS IS 5" (OVERALL), OVER 15 MIL VAPOR RETARDER, UNLESS NOTED OTHERWISE.
 5. EXISTING FRAMING INFORMATION IS PROVIDED FOR THE CONTRACTOR'S CONVENIENCE ONLY. IT IS BASED ON EXISTING DRAWINGS, AND MAY NOT ACCURATELY REFLECT THE ACTUAL CONDITIONS IN THE FIELD. INTELLIGENT ENGINEERING SERVICES, LLP MAKES NO GUARANTEE CONCERNING THE ACCURACY OF THE INFORMATION CONTAINED HEREIN, FIELD VERIFY ALL CONDITIONS.

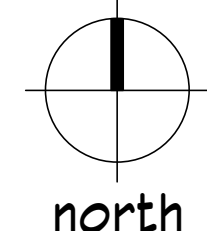
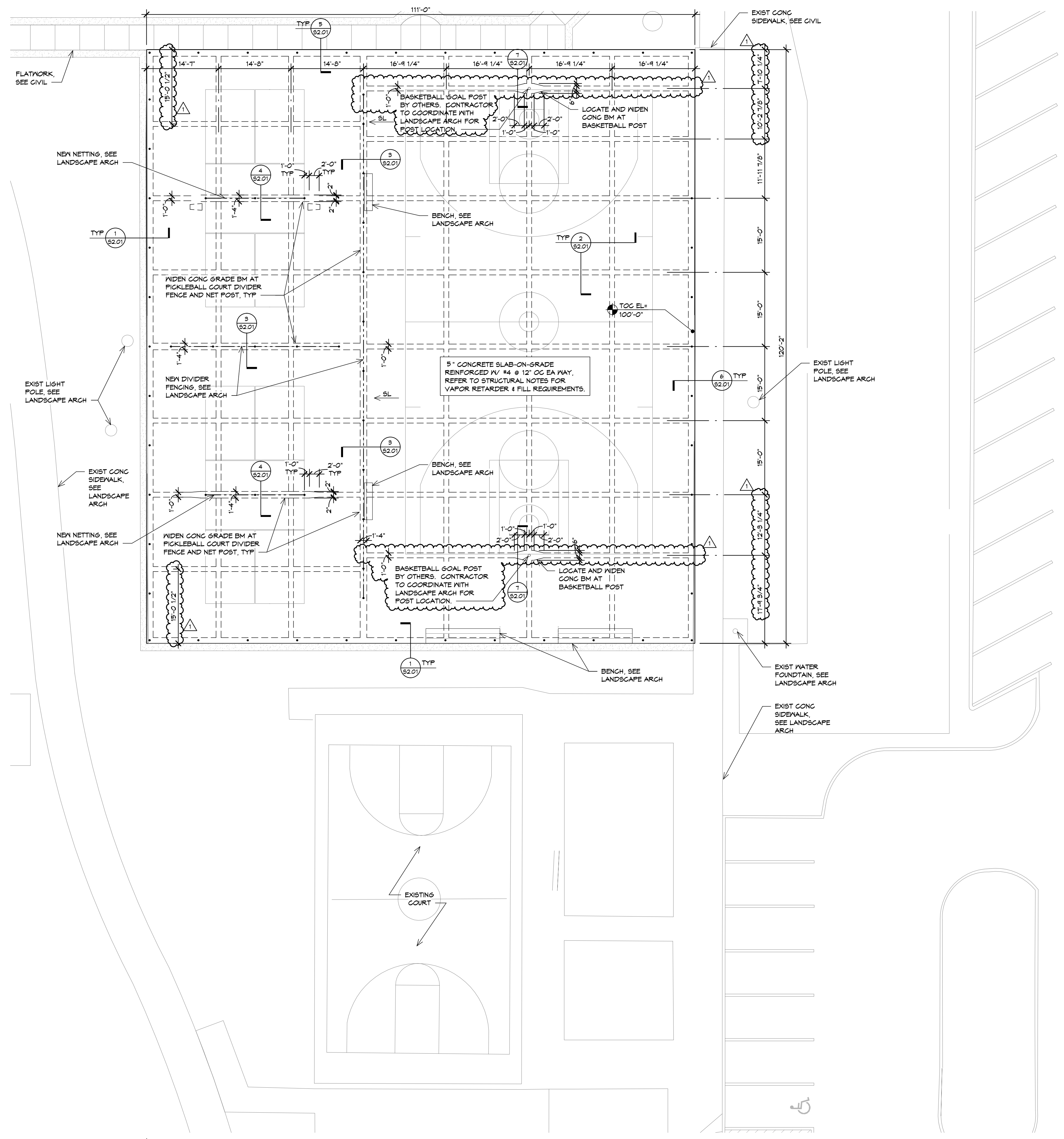

1 FOUNDATION PLAN - PICKWELL PARK
SCALE: 3/32" = 1'-0"

1/10/2025 12:23:17 PM C:\Users\araceli\Documents\2350_COSA Multiple Parks Pickleball Court Assessment_Central_R24_amentalvo@ie-services.com.rvt

INTERIM REVIEW ONLY

Document incomplete; Not intended for permit, bidding or construction.

DATE: 07/26/24
LANDSCAPE ARCHITECT: Dorin Weinheimer
REGISTRATION: 1643

Date: Revisions/Submissions

12/15/23	Issue for DD
08/08/24	Issue for CD
08/22/24	Issue for Bid
09/12/24	Issue for Owner Review
01/10/25	Addendum 2

CITY OF SAN ANTONIO
TRANSPORTATION AND CAPITAL IMPROVEMENTS
VERTICAL PROJECT MANAGEMENT DIVISION
MUNICIPAL PLAZA BUILDING 114 W. COMMERCE
P.O. BOX 839666 SAN ANTONIO, TX 78283-3966
TEL. (210) 207-2879 FAX (210) 207-2197

DISTRICT 3: PICKWELL
6911 PICKWELL DR.
SAN ANTONIO, TEXAS 78223



Drawn By:
VG

Date:
09/12/2024

Project No.:
23-04013

Sheet Name:
CONCRETE SECTIONS

Sheet Number:
S2.01

INTELLIGENT ENGINEERING SERVICES
ENGINEERING COMMUNITIES FROM THE GROUND UP
1045 CENTRAL PARKWAY NORTH, SUITE 200 SAN ANTONIO, TEXAS 78202
210.349.9098 ee-services.com

IES JOB NO. 1233250 TBPE FORM-F-432

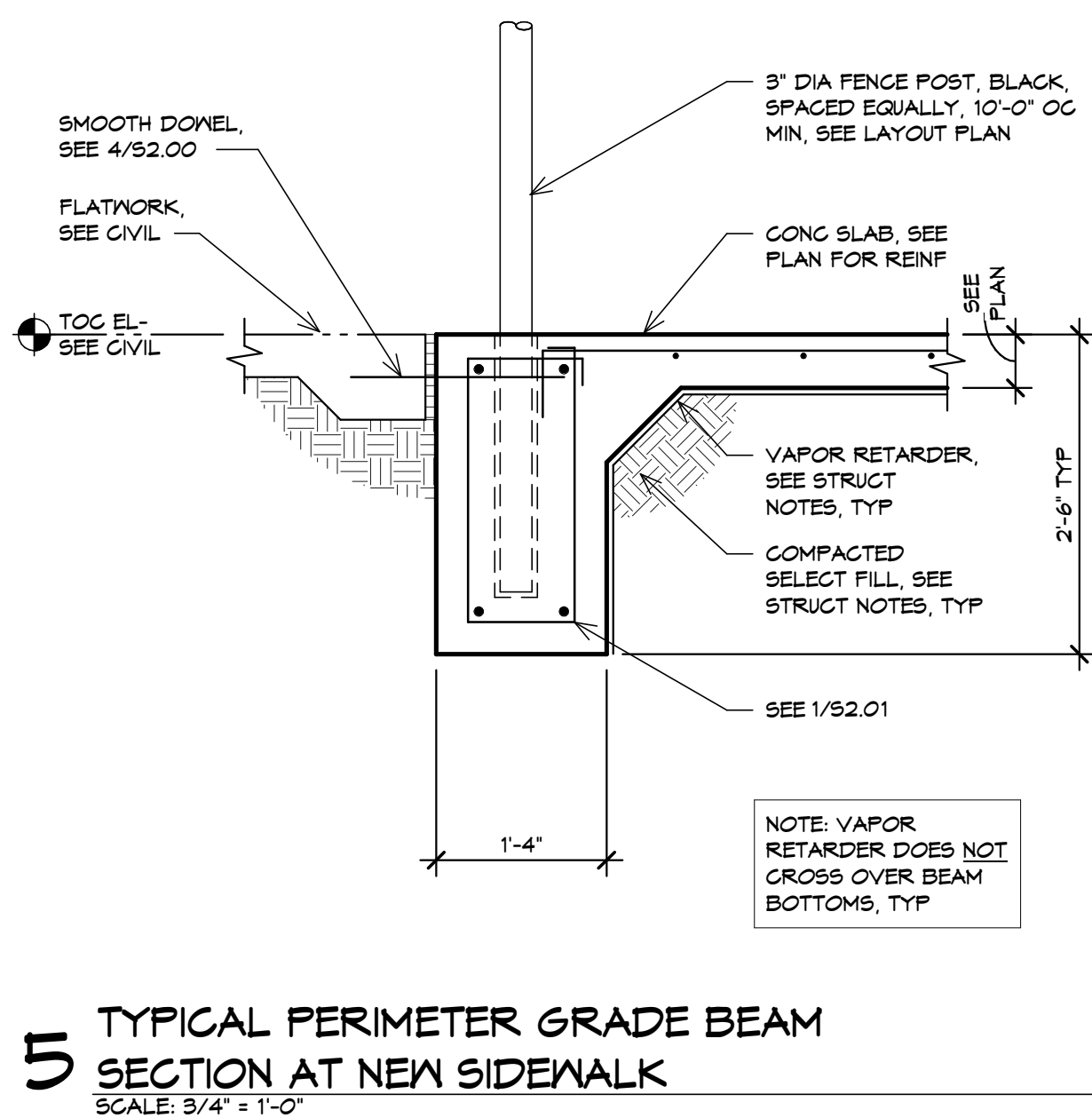
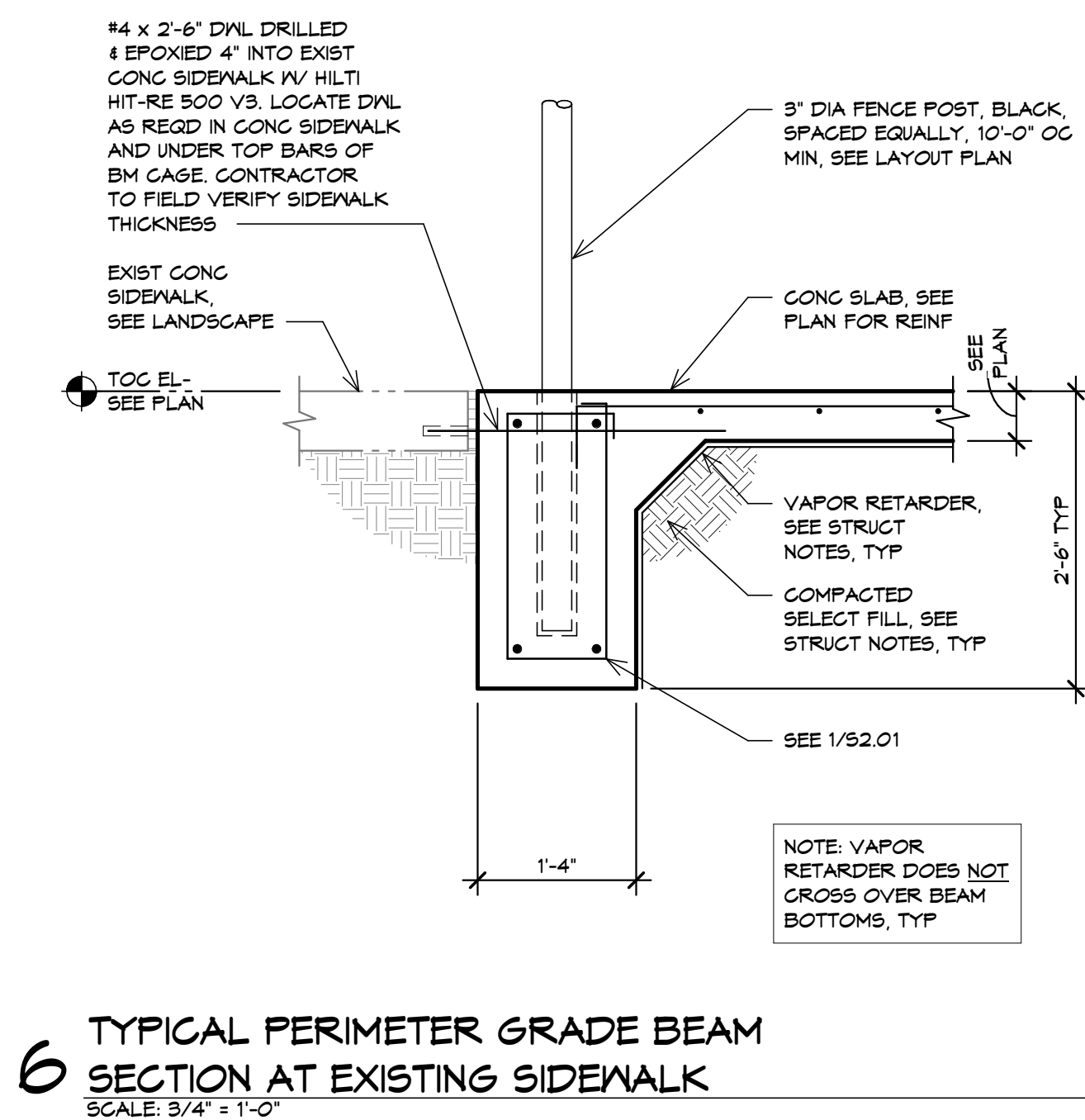
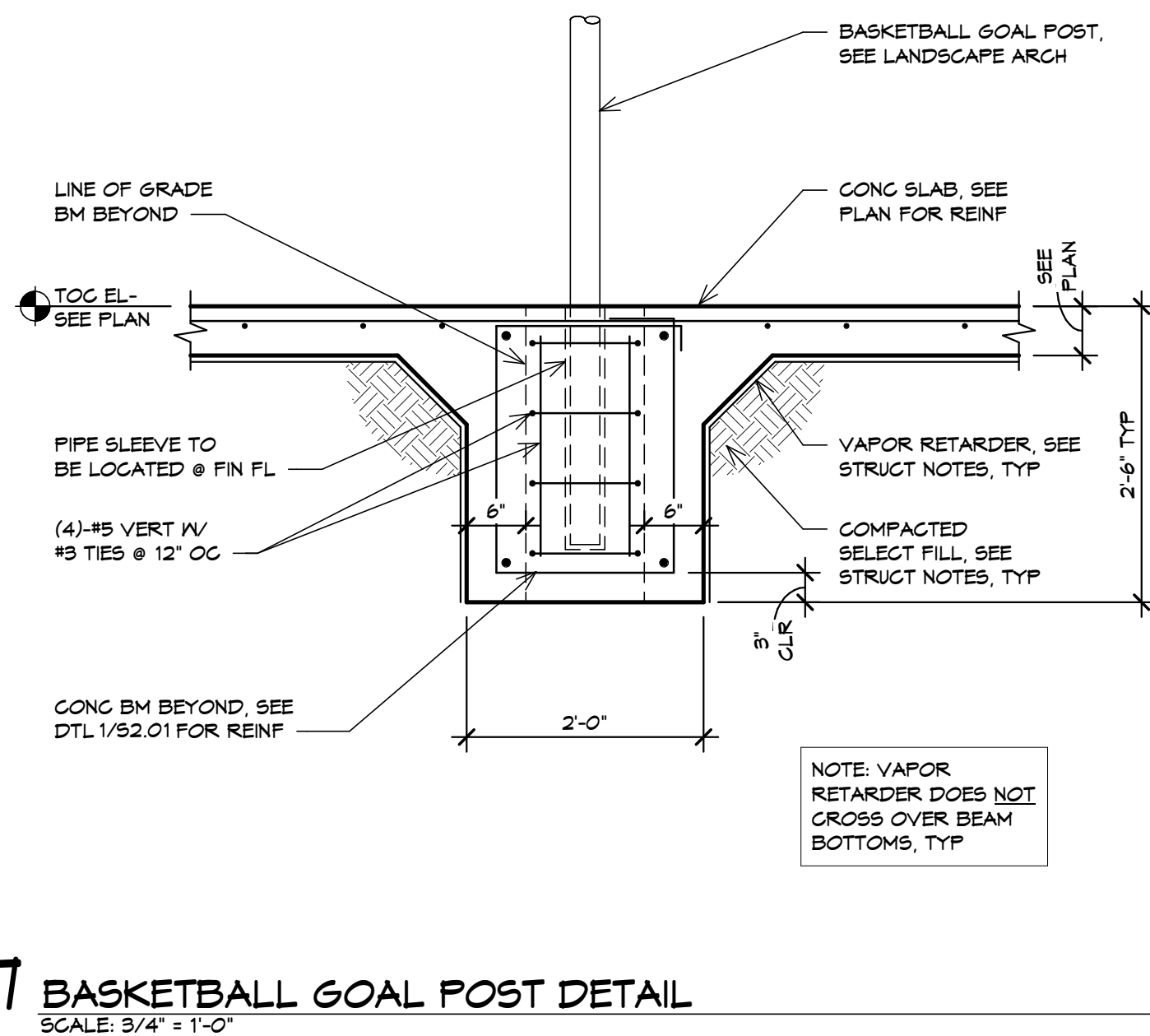
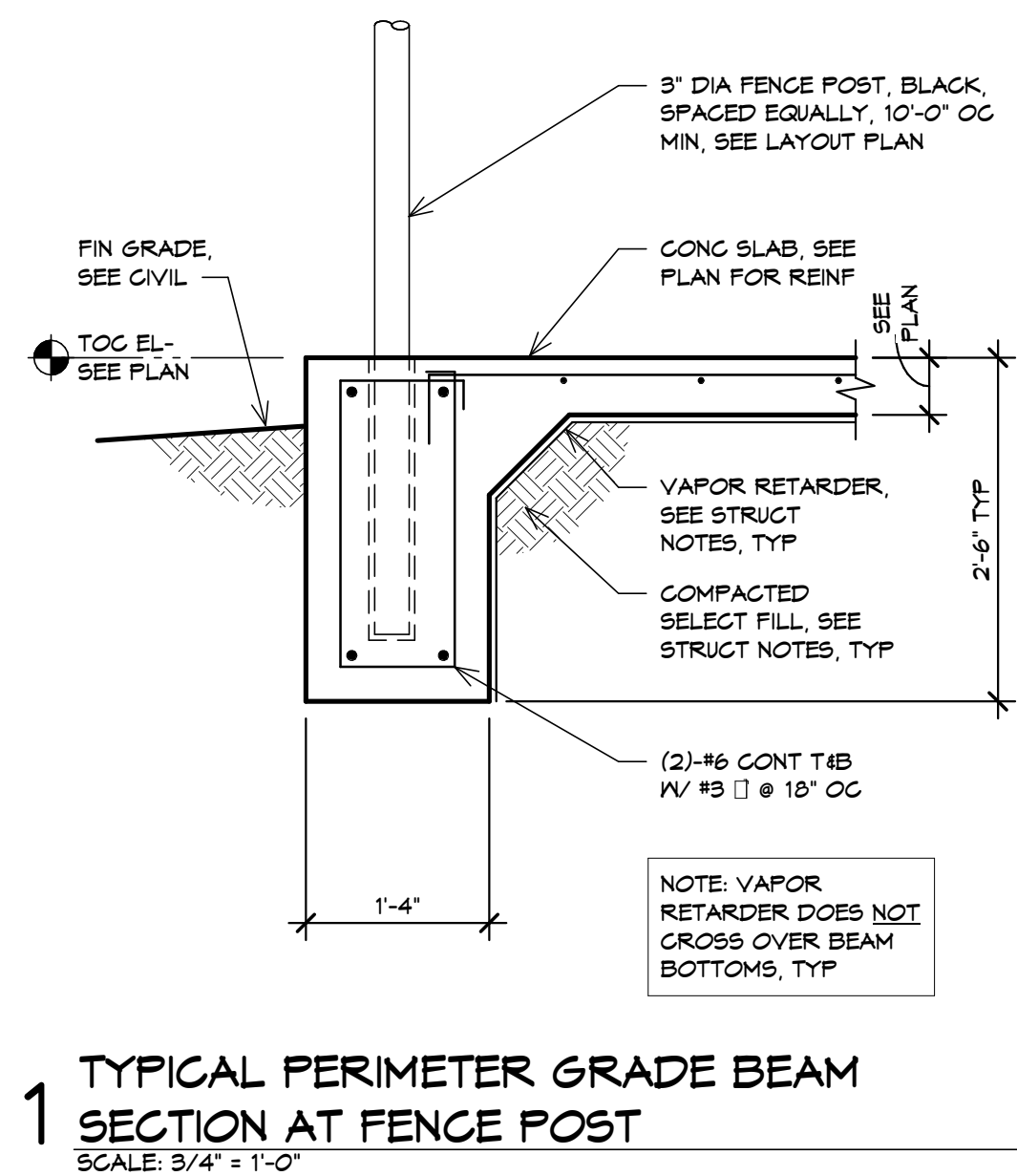
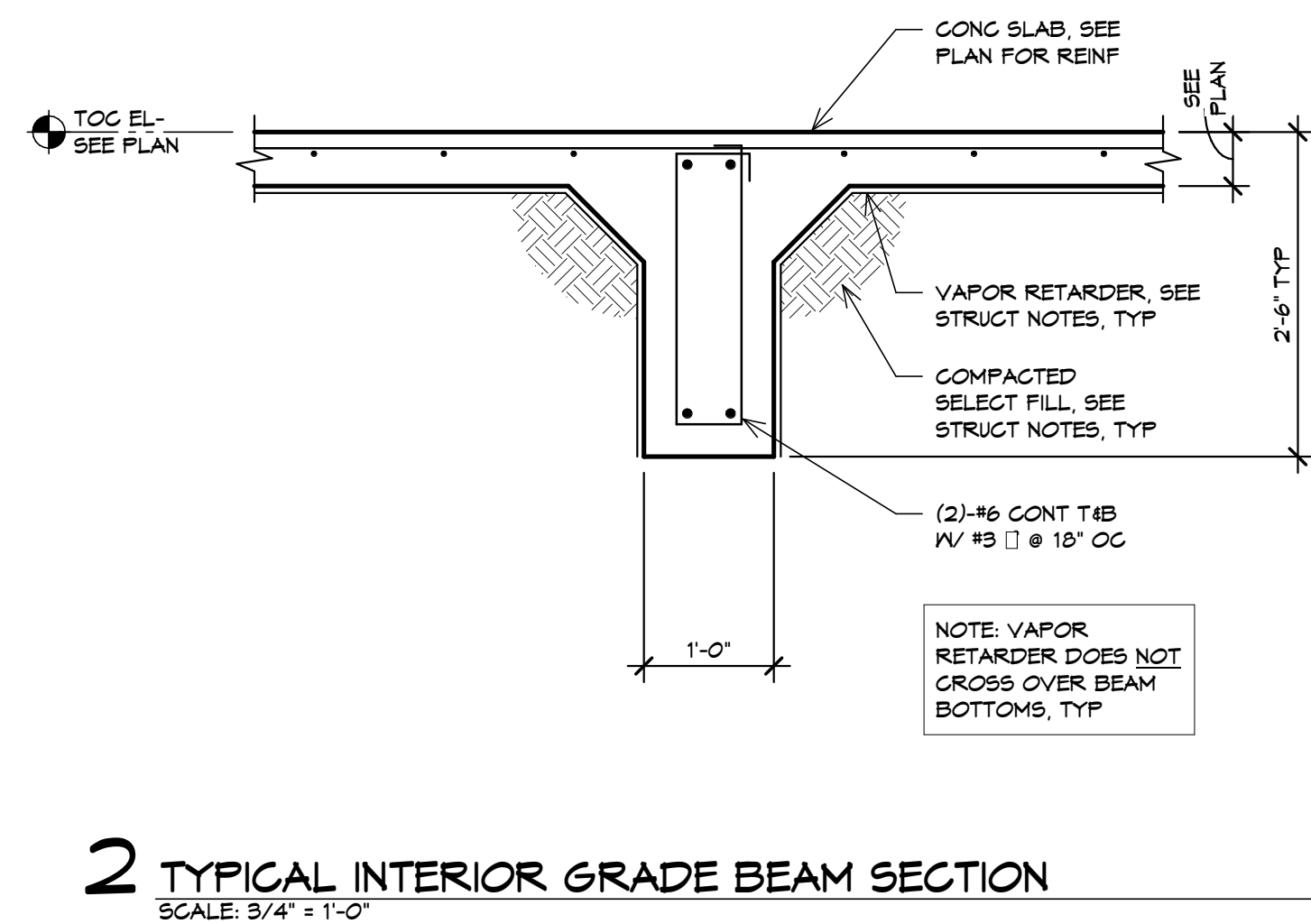
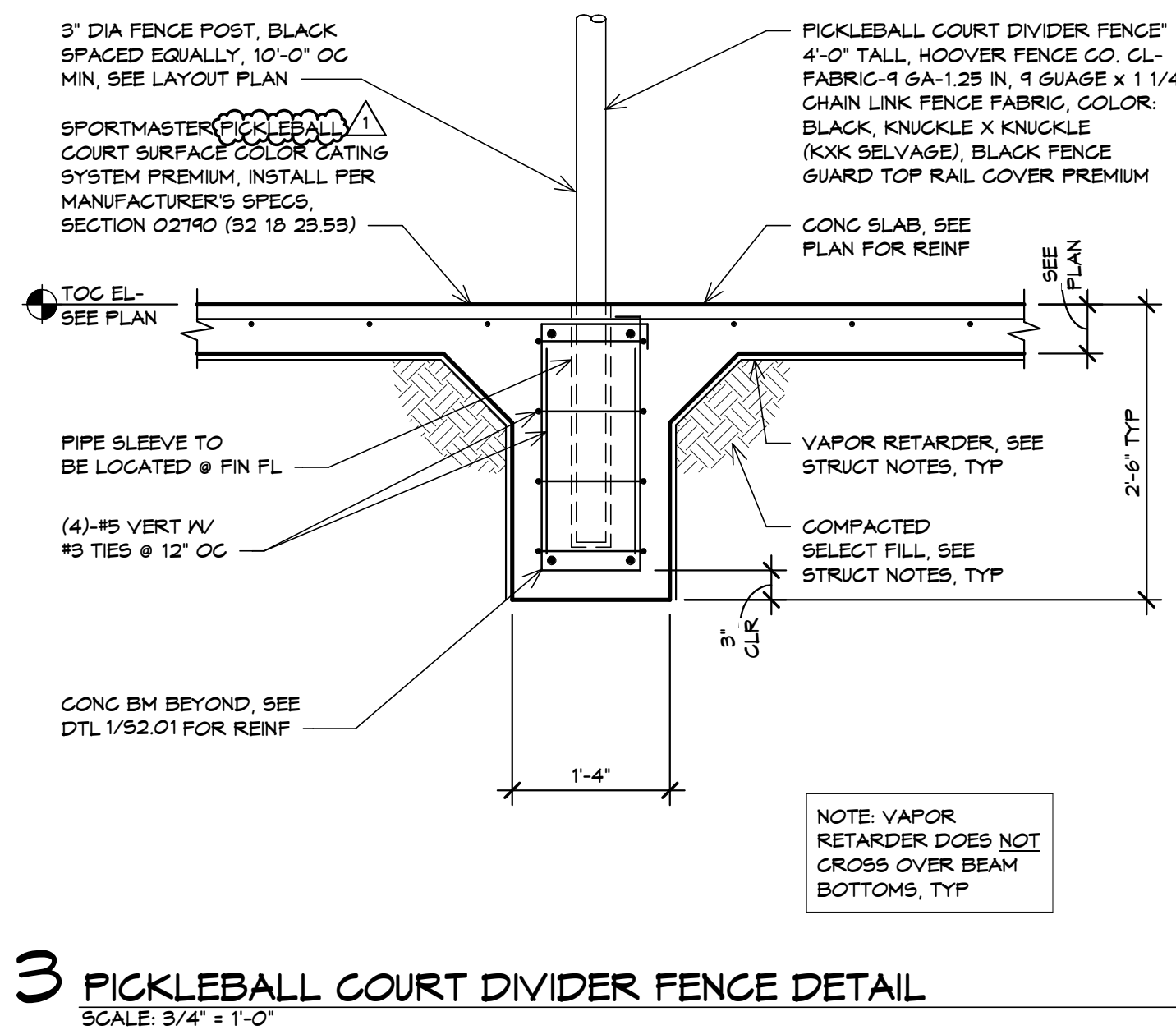
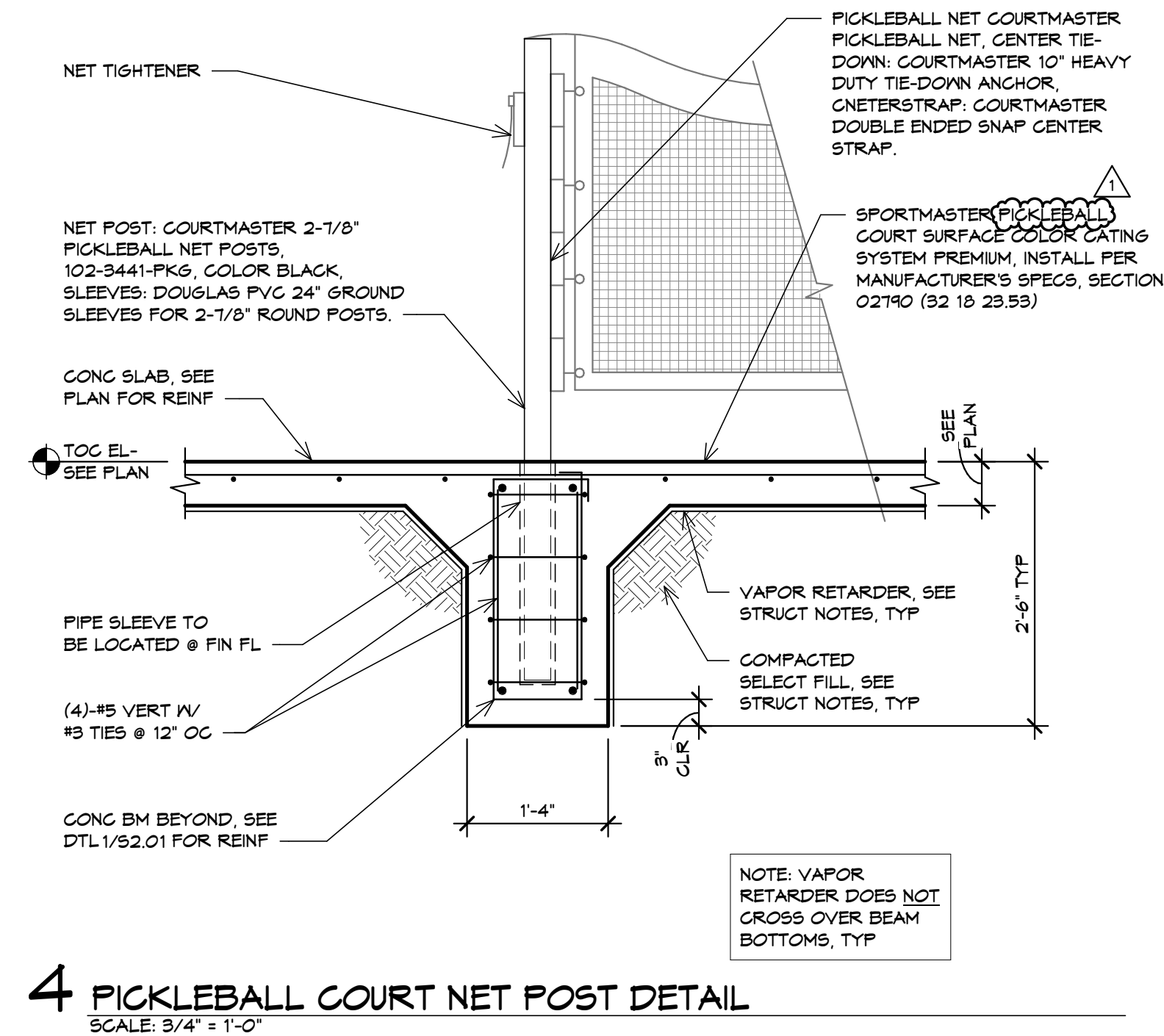

C:\Users\araceli\Documents\2350_COSA Multiple Parks Pickleball Court Assessment_Central_R24_amtalvalvo@e-services.com.rvt

1/10/2025 12:23:18 PM



Pickwell Park Bond Improvements – Base Bid B Project #23-04014

Specifications

9/27/24

City of San Antonio:

Assistant Capital Programs Manager, Parks and Open Space Team

Desiree Salmon, PLA, MLA

e. Desiree.Salmon@sanantonio.gov

p. 210-207-2113 (o)

Consultant: KW Landscape Architects

KW Director of San Antonio: Kristen Guinn, PLA

e. KGuinnr@KWTexas.com

p. 210.610.7103

**PROJECT MANUAL
FOR**

**PICKWELL PARK BOND IMPROVEMENTS – BASE BID B
San Antonio, Texas**

OWNER:

City of San Antonio
Public Works Department
Contact: Desiree Salmon
100 W. Houston St, Street Level
San Antonio, Texas 78205

CIVIL ENGINEER:

WGI
Contact: Adrian Garcia
755 E. Mulberry Ave, Suite 501
San Antonio, Texas 78212
210.860.9224

LANDSCAPE ARCHITECT (PICKLEBALL):

KW Landscape Architects
Contact: Kristen Guinn
4039 Broadway Street
San Antonio, TX 78209
210.610.7103

STRUCTURAL ENGINEER:

Intelligent Engineering Services
Contact: Vince Guerra
1045 Central Parkway North, Suite 200
San Antonio, TX 78232
210.238.6770

DOCUMENT SEALS PAGE

Issued for:

100% Bid Documents

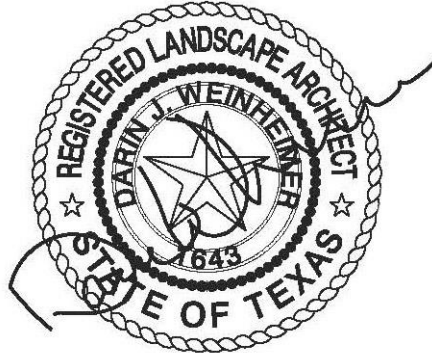

KW Landscape Architects
4039 Broadway Street
San Antonio, TX 78209

09/27/2024

LANDSCAPE ARCHITECTURAL RESPONSIBILITY

SPECIFICATION SECTIONS:

SECTION 329119	FINISH GRADING
SECTION 129300	SITE FURNISHINGS
SECTION 32 91 13	SOIL PREPARATION
SECTION 322923	LAWN SODDING
SECTION 033013	LANDSCAPE CAST-IN-PLACE CONCRETE
SECTION 320190.13	LANDSCAPE MAINTENANCE
SECTION 32 18 23.53	PICKLEBALL COURT SURFACING SYSTEM

23-04014 Pickwell Park Specifications
September 27, 2024

SECTION 329119 – FINISH GRADING

PART 1 - GENERAL

1.1 DESCRIPTION

- A. Work includes: weeding and finish grading of lawn and planting areas.
- B. Related work:
 - 1. Section 03 33 13: Landscape Cast-In-Place Concrete.
 - 2. Section 32 90 00: Planting Materials.
 - 3. Section 32 91 13 Planting Soil Preparation and Planting Soil Mix Designs.

1.2 DEFINITIONS:

- A. Finish grading: finish grading shall consist of adjusting and finishing soil surfaces with site or imported topsoil, raking grades to a smooth, even, uniform plane. Remove and legally dispose of all extraneous matter off site. Facilitate natural run-off water and establish grades and drainage indicated as part of the contract work.
- B. The word Architect as used herein shall refer to the Landscape Architect or the Owner's authorized representative.

PART 2 - PRODUCTS

2.1 MATERIALS:

- A. Import Top Soil: Import top soil shall be classified as sandy loam, and must conform to the following:

1. Particle size

Class	Particle Size Range	Maximum %	Minimum %
Coarse sand	0.5 - 2.0mm	15	0
Silt plus clay	<0.05mm	50	15
Other classes:			
Gravel	2-13mm	15	0
Rock	1/2 - 1"	5% by volume with none > 1"	

2. Chemistry

- a. Salinity: Saturation Extract Conductivity (ECe) - less than 3.0 sD/m @ 25° C
- b. Sodium: Sodium Absorption Ratio (SAR) - less than 6.0
- c. Boron: Saturation Extract Concentration - Less than 1.0 ppm
- d. Reaction: pH of Saturated Paste - 5.5-7.8 without high lime content

- 3. Soil shall contain sufficient quantities of available nitrogen, phosphorus, potassium, calcium and

magnesium to support normal plant growth. In the event of nutrient inadequacies, provisions shall be made to add required material prior to planting.

- B. In order to insure conformance, samples of the import soil shall be submitted to an approved laboratory for analysis prior to and following backfilling.
- C. Obtain imported topsoil from approved local sources.

PART 3 - EXECUTION

3.1 EXAMINATION:

- A. Verification of conditions: Prior to commencing the finish grading, review the installed work of other trades and verify that their work is complete.
 - 1. Rough Grading: Grading in planting areas (except raised planter areas) shall be established to within plus or minus 0.10 foot prior to beginning of finish grading.
 - 2. Moving onto the site and/or commencing work shall be construed as acceptance of rough grade conditions by the Contractor.
- B. Import topsoil only when necessary to supplement site soil to achieve grades shown on Drawings, or if site soil is unsuitable for planting.

3.2 PREPARATION:

- A. Weeding: Before finish grading, weeds and grasses shall be dug out by the root or sprayed with an herbicide and disposed of off-site. This procedure is outlined under the Landscape Planting Section.
- B. Debris: Remove stones and debris 1 inch in diameter and greater and clumps of earth that do not break up. Dispose of off-site.

3.3 INSTALLATION:

- A. General: When rough grading and weeding have been completed, and the soil has dried sufficiently to be readily worked, lawn and planting areas shall be graded to the elevations indicated on the Drawings.
 - 1. Grades indicated on Drawing are grades that will result after thorough settlement and compaction of the soil.
 - 2. Grades not otherwise indicated shall be uniform finish grades and, if required, shall be made at the direction of the Architect.
 - 3. Finish grades shall be smooth, even, and a uniform plane with no abrupt change of surfaces.
 - 4. Soil areas adjacent to buildings shall slope away from the building to allow a natural run-off of water, and surface drainage shall be directed as indicated on the drawings by remodeling surfaces to facilitate the run off water at 2% minimum grade.
 - 5. Low spots and pockets shall be graded to drain properly.
- B. Drainage: Finish grade with proper slope to drains.

1. Flow lines, designated or not, shall be graded and maintained to allow free flow of surface water.
2. If any drainage problems arise during construction period due to Contractor's work (such as, but not limited to, low spots, slides, gullies and general erosion), the Contractor shall be responsible for repairing these areas to a condition equal to their original condition, and in so doing shall prevent further drainage problems from occurring.
- C. Toe of slope: To prevent soil creep or erosion across pavement, where pavement (walk, curb, etc.) is at the toe of a slope, finish grade is to level out or swale slightly at least 6" before reaching pavement
- D. Moisture Content: The soil shall not be worked when the moisture content is so great that excessive compaction occurs, nor when it is so dry that dust may form in the air or that clods do not break readily. Water may be applied, if necessary, to provide moisture content for tilling and planting operations. It is the Contractor's responsibility to control dust that is spread as a result of grading operations.
- E. Grades: The finish grade shall be 1-1/2 inch below grade of adjacent pavement, walks, curbs, or headers except when drainage conditions require flush grades, as directed by the Owner's Representative, or if otherwise indicated on Drawings.
- F. Compaction: Soils in planted areas shall be loose and friable, yet firm enough that no settling occurs from normal foot traffic or irrigation.

3.4 FIELD OBSERVATION:

- A. Contact the Architect 48 hours or two working days in advance of each agreed observation or conference.
- B. Schedule for On-Site Reviews: At completion of finish grading and prior to any planting operations.

END OF SECTION

SECTION 129300 – SITE FURNISHINGS

PART 1 - GENERAL

1.1 SUMMARY

- A. This Section includes materials, labor, apparatus, tools, equipment, temporary construction, transportation, and services necessary for and incidental to performing the proper completion of Work for Site and Street Furnishings, as shown on the Contract Drawings, and as specified herein this Section.
- B. Work under this Section consists of, but is not necessarily limited to, furnishing and installing the following:
 - 1. Bleacher (J1).
 - 2. Paddle Rack (J2).
 - 3. Trash Receptacle (J3).
 - 4. Bench (J4).
 - 5. Play Signage – Fixed (J5).
- C. Related Sections: The following Sections contain requirements of Work that relate to this Section:
 - 1. Section 329113 – Soil Preparation.
 - 2. 320190.13 Landscape Maintenance for 90 Days

1.2 SUBMITTALS

- A. General: Submit four (4) bound booklets, hard copies or digital copies. Each booklet under this Section shall be tabbed into specific sections, containing clearly identified (through yellow highlighter or other identification methods) and legible information on the following required information indicated herein this Section.
- B. Shop Drawings to show component parts, fabrication, installation, and dimensions for items indicated herein this Section.
- C. Samples:
 - 1. Submit manufacturer's product data for review, including color charts.
 - 2. Samples of complete Units or parts of Units of the items indicated herein this Section shall be furnished, as requested by Landscape Architect, for review and approval.
 - 3. Submit manufacturer's written certification that each product complies with specified requirements noted herein.
- D. Certification: Provide certification from each manufacturer, as specified herein this Section, that their product(s) meet the specific criteria associated for sustainable products.
- E. Submittals may be rejected if they are difficult to read due to insufficient scale, poor image quality, or poor drafting quality; or if the required information is not included.
- F. Work shall not proceed until Submittals have been reviewed and approved by the Landscape Architect.

1.3 QUALITY ASSURANCE AND CONTROL

- A. All materials and Work shall be in accordance with the State Codes and Specifications and other criteria herein specified.
- B. Single-Source Responsibility: Obtain furnishing Units from each respective single source with resources to provide products and materials of consistent quality in appearance and physical properties without delaying the Work.
- C. Substitutions: Unit(s) to be considered equal to those specified herein this Section shall be reviewed and approved by the Landscape Architect, in writing, prior to the Bid Date. No substitutions shall be allowed after the Bid Date.

1.4 COORDINATION

- A. Contractor shall coordinate the installation of all furnishings in this Section with all other related Work of this Contract.
- B. Contractor shall be responsible for verifying the dimensions and required hardware of the furnishings prior to commencing installation Work.
- C. Coordinating furnishing footings with utility locations. Note potential conflicts to the Landscape Architect.

1.5 DELIVERY, STORAGE AND HANDLING

- A. Furnishings shall be stored as necessary to prevent damage and shall be in new condition when ready for installation. It shall be the responsibility of the Contractor to install "factory condition" furnishings.

PART 2 - PRODUCTS

- 2.1 See Drawings.

PART 3 - EXECUTION

3.1 INSPECTION

- A. Examine the areas and conditions under which site furnishing units are to be installed and remedy any conditions detrimental to the proper and timely completion of the Work. Do not proceed with the Work until unsatisfactory conditions have been corrected in a manner acceptable to the Landscape Architect.

3.2 INSTALLATION

- A. Units J1-J5 (refer to the drawings).
1. Bleacher, Paddle Rack, Trash Receptacle, Bench and play Signage shall be furnished and located as shown on the Contract Drawings, and as directed by the Contract Specifications. Verify exact locations (both at ground level and on-structure) with the Landscape Architect prior to installation.
 2. Use actual Unit(s) to establish all dimensions for installation.
 3. Erect and install Unit(s) in accordance with the Manufacturer's instructions and recommendations. Install unit(s) plumb, accurately, and in the correct orientation and relationship with other site furnishings, elements and/or paving as shown on the Contract Drawings.
 4. Install all anchorage and mounting hardware, as applicable, in strict accordance with Manufacturer's instructions, and as directed by the Landscape Architect.

3.3 PROTECTION

- A. Protect installed furnishings against damage throughout the duration of the construction period, complying with Manufacturer's directions.
- B. Touch-up Painting: Immediately after erection, clean field welds, bolted connections, and abraded areas of the work. Paint exposed areas with paint or other material as supplied by the Manufacturer of the damaged Unit. Apply by brush, to thickness recommended by paint manufacturer.

END OF SECTION 129300

SECTION 32 91 13 - SOIL PREPARATION

PART 1 GENERAL

1.1 SUMMARY

- A. Section Includes:
 - 1. In-Place Amendment of Planting Area Soil Surfaces.
 - 2. Plant Pit Backfill Mix.
- B. Related Sections:
 - 1. Section 32 01 90, Landscape Maintenance Period.
 - 2. Section 32 91 19, Planting Area Finish Grading.
 - 3. Section 32 92 23, Lawn Sodding.

1.2 REFERENCES

- A. ASTM — ASTM International: D 1557 — Test Method for Laboratory Compaction Characteristics of Soil Using Modified Effort.
- B. USDA — United States Department of Agriculture:
 - 1. Soil Texture Triangle Classification.
 - 2. Handbook No. 60.

1.3 DEFINITIONS

- A. Acceptance, Acceptable, or Accepted: Acceptance by the Landscape Architect in writing.
- B. Excessive Compaction: Planting area soil compaction greater than 75 percent of maximum dry density as determined by ASTM D 1557.
- C. Horticultural Consultant: Horticultural consultant employed by Landscape Architect for Project.
- D. Landscape Architect: Landscape Architect employed by the Owner to provide professional landscape architectural services for the Project.
- E. Drip Line: Line straight down from outermost limit of tree canopy branching.

1.4 SYSTEM DESCRIPTION

- A. Backfill Mixes and Amended Planting Area Surface Soil: Uncompacted on-site soil with amendments incorporated uniformly to provide a well-draining, fertile medium for vigorous plant root growth.

- B. Soil Mixes: Uncompacted, imported topsoil with amendment incorporated uniformly to provide a well-draining, fertile medium for vigorous plant root growth.

1.5 SUBMITTALS

- A. General Requirements: Refer to Division 1.
- B. Product Data:
 - 1. Chemical Amendments.
 - 2. Organic Soil Conditioner.
 - 3. Fertilizers.
 - 4. Organic Amendment.
- C. Test Reports:
 - 1. Laboratory soil test reports indicating specified characteristics of soil, with test date no more than 2 weeks old.
 - 2. Laboratory test report of organic amendment indicating specified characteristics of organic amendment, with test date no more than 2 weeks old.
- D. Purchase Documentation:
 - 1. Fertilizer Purchase and Delivery Invoices.
 - 2. Chemical Amendment Purchase and Delivery Invoices.

1.6 QUALITY ASSURANCE

- A. Requirements of Regulatory Agencies:
 - 1. Meet requirements of applicable laws, codes, and regulations required by authorities having jurisdiction over Work.
 - 2. Provide for inspections and permits required by federal, state and local authorities in furnishing, transporting, and installing materials.

1.7 SITE CONDITIONS

- A. Environmental Requirements:
 - 1. Do not work soil when moisture content is so great that excessive compaction will occur, nor when it is so dry that dust will form in the air or that clods will not break readily.
 - 2. Apply water, if necessary, to bring soil to an optimum moisture content for tilling.
 - 3. Do not work soil when muddy or frozen.
 - 4. Do not apply chemicals if wind conditions will cause hazardous drift to people or property.

B. Existing Conditions:

1. Prior to Work commencement review and clearly mark in field horizontal and vertical locations of existing public underground utilities and structures with respective utility companies.
2. Prior to Work commencement review and clearly mark in field horizontal and vertical locations of existing private underground utilities and structures with the Owner's Designated Representative.

PART 2 PRODUCTS

1.1 SOIL

A. Site Soil:

1. Site soil used to form landscape planting areas or backfill planters shall be clean, fertile, loamy soil, free of stones, sticks, stumps, or other deleterious matter one inch in diameter or larger. It shall also be free from wire, plaster, construction debris, or similar objects that would be a hindrance to planting or maintenance.
2. Polymeric Soil Conditioner: Twenty to 25 percent anionic polyacrylamide, water-soluble, linear, 7,500,000- dalton, soil aggregating polymer containing a minimum of 20,000 soil binding sites proven to be efficacious.
3. The Architect shall approve suitability of soil of the site after reviewing results of the soil test.

B. Import Top Soil: See Finished Grading Section 32 91 16.

2.1 ACCEPTABLE MANUFACTURERS AND SUPPLIERS

A. Fertilizers:

1. Roots, Inc., Independence, Mo.; (800) 342-6173; www.rootsinc.com.
2. Vermi Technology Unlimited, Orange Lake, Fla; (352) 591-1111; www.vermitechnology.com.
3. Kelly's Green Team, Newark, Mo.; (660) 627-5500; www.kellysgreenteam.com.

2.2 MATERIALS

A. Organic Amendment:

1. Humus material shall have an acid-soluble ash content of no less than 5 percent and no more than 20 percent.
2. The pH of the material shall be between 6 and 7.5.
3. The salt content shall be less than 10 millimho/cm at 25 degrees C on a saturated paste extract.
4. Boron content of the saturated extract shall be less than 1.0 part per million

5. Silicon content (acid-insoluble ash) shall be less than 50 percent.
6. Calcium carbonate shall not be present if the amendment is to be applied on alkaline soils.
7. Types of acceptable products are composts, manures, mushroom composts, straw, alfalfa, peat mosses, etc., low in salts, low in heavy metals, free from weed seeds, free of pathogens and other deleterious materials.
8. Composted wood products are conditionally acceptable (stable humus must be present). Wood-based products are not acceptable which are based on redwood or cedar.
9. Sludge-based materials are not acceptable.
10. Carbon-nitrogen ratio shall be less than 25:1. The compost shall be aerobic without malodorous presence of decomposition products.
11. The maximum particle size shall be 0.5-inch and 80 percent or more shall pass a No. 4 screen for mixing with soil. The maximum particle size for applying via hydroseeding machine shall be 0.25-inch.
12. Maximum total permissible pollutant concentrations in organic amendment in parts per million on a dry-weight basis:

Arsenic:	20
Cadmium:	15
Chromium:	300
Cobalt:	50
Copper:	150
Lead:	200
Mercury:	10
Molybdenum:	20
Nickel:	100
Selenium:	50
Silver:	10
Vanadium:	400
Zinc:	250

Higher amounts of salinity or boron may be present if the soils are to be pre-leached to reduce the excess or if the plant species will tolerate the salinity and/or boron.

13. From 45- to 65-percent moisture measured via wet-weight basis.
14. Free of stones and debris.

15. Tests 5 to 8 on Solvita Test.

B. Fertilizers:

1. Roots “M-Roots” with mycorrhiza 3-3-3.
2. Kelley’s Green Team Gypsum Fairway Pellets, 76-percent calcium sulphate dehydrate, 17-percent calcium; 14- percent sulphur, derived from mined gypsum, less than 1-percent moisture content.
3. Vermi Technology pure black worm castings produced without waste products; free of larva, sticks, stones, and debris; 48 percent by weight minimum organic content per ASTM D2974; complying with the following:

<i>Item</i>	<i>Criteria</i>
Total Ash	48% to 52%
pH:	5.0 to 7.5
% Moisture (wet wt. basis:	30% to
50% Solvita Rating:	> 8

C. Potential Chemical Amendments Required by Accepted Amendment Program and Backfill Mix:

1. Ground Limestone: Agricultural limestone containing not less than 85 percent of total carbonate, ground to such fineness that 50 percent will pass No. 1 sieve and 90 percent will pass No. 20 sieve.
2. Dolomite Lime: Agricultural grade mineral soil conditioner containing 35 percent minimum magnesium carbonate and 49 percent minimum calcium carbonate, 100 percent passing No. 65 sieve.
3. Gypsum: Agricultural grade product containing 80 percent minimum calcium sulfate.
4. Iron Sulfate (Ferric or Ferrous): Supplied by a commercial fertilizer supplier, containing 20 to 30 percent iron and 35 percent to 40 percent sulfur.
5. Sulfate of Potash: Agricultural grade containing 50 to 53 percent of water-soluble potash.
6. Single Superphosphate: Commercial product containing 20 to 25 percent available phosphoric acid.
7. Ammonium Sulfate: Commercial product containing approximately 21 percent ammonia.
8. Ammonium Nitrate: Commercial product containing approximately 34 percent ammonia.
9. Calcium Nitrate: Agricultural grade containing 15-1/2 percent nitrogen.
10. Urea Formaldehyde: Granular commercial product containing 38 percent nitrogen.

11. IBDU (Iso Butyldiene Diurea): Commercial product containing 31 percent nitrogen.
12. Soil Sulfur: Agricultural grade sulfur containing a minimum of 96 percent sulfur.
13. Silicic Acid Calcium: Commercial grade.

2.3 MIXES

- A. Preliminary Plant Pit Backfill Mix to Establish Bid (actual quantities contingent on amendment program determined by the Landscape Architect and Horticultural Consultant based on soil test report):

1. Content:

- a. 8 cubic feet of organic amendment per cubic yard of dry soil.
- b. 1-pound dry polymeric soil conditioner per cubic yard of dry soil.
- c. 2 pounds Iron Sulfate per cubic yard of dry soil.
- d. 1-pound granular Micromax per cubic yard of dry soil.
- e. 1/2-pound Triple Superphosphate 0-45-0 per cubic yard of dry soil.
- f. 1-pound of Nitroform 38-0-0 per cubic yard dry soil.
- g. 1-pound of Potassium Sulfate 0-0-50 per cubic yard dry soil.

2. Mixing:

- a. Blend materials uniformly with 50 percent dry existing soil excavated from plant pits and 50 percent dry imported topsoil in bulk by turning over materials with an end loader.
- b. Blend materials in a clean area which will not contaminate mix.
- c. Do not mix in planting areas.

- B. Final Plant Pit Backfill Mix for Installation: Backfill mixes determined by the Landscape Architect and Horticultural Consultant upon review of the soil test report.

- C. Preliminary In-Place Amendment of Planting Area Surfaces to Establish Bid (actual quantities contingent on amendment program determined by the Landscape Architect and Horticultural Consultant based on soil test report):

- D. Final In-Place Amendment of Planting Area Surfaces: Determined by the Landscape Architect and Horticultural Consultant upon review of the soil test report.

2.4 SOURCE QUALITY CONTROL

- A. Organic Amendment: Employ independent soil testing laboratory to test organic amendment for

specified properties and submit test results.

PART 3 EXECUTION

3.1 EXAMINATION

- A. General: Examine site and verify that conditions are suitable to receive Work and that no defects or errors are present which would cause defective installation of products or cause latent defects in workmanship and function.
- B. Subgrade: Verify that the subgrade is at the correct elevation and slope.
- C. Underground Utilities and Structures: Verify that the locations of utilities, structures and other underground items have been clearly marked.
- D. Notification of Unsuitable Conditions: Before proceeding with Work, notify the Owner's Designated Representative in writing of unsuitable conditions and conflicts.
- E. Soil Tests to Determine Final Plant Pit Backfill Mix, Planting Area Soil Surface Amendment Programs, and Maintenance Period Fertilization Programs:
 - 1. Take fifteen 1-pound composite representative soil samples from locations determined by the Architect/Engineer in the field.
 - 2. Send samples to Wallace Laboratories, 365 Coral Circle, El Segundo, CA 90245, and employ the laboratory to test the soil samples for the following or approved equal:
 - a. pH measurement in the saturation extract per USDA Handbook No. 60, Method 21.
 - b. Electrical conductivity of the saturation extract per USDA Handbook No. 60, Method 2.
 - c. Sodium absorption ratio of the saturation extract per USDA Handbook No. 60, Method 20b.
 - d. Determination of boron, calcium, copper, iron, magnesium, manganese, molybdenum, phosphorous, potassium, sodium, sulfur, and zinc, via the following test methods: Mehlich Number 3, Bray P1, Bray P2, Olsen P, DTPA, ammonium acetate, ammonium bicarbonate DTPA, and hot water extract from boron.
 - e. Analysis of saturation extract for calcium, magnesium, sodium, boron, chloride, phosphorous, nitrate, and sulfate.
 - f. Measurement of following trace metals by the DTPA extract: aluminum, arsenic, cadmium, chromium, cobalt, lead, lithium, nickel, selenium, silver, strontium, tin, and vanadium.
 - g. Presence of calcium carbonate and magnesium carbonate.
 - h. Estimate of soil texture per commonly used methods.

- i. Estimate of organic matter content per commonly used methods.
 - j. Exchangeable Ammonium Cation.
 - k. Base Saturation.
 - l. Cation Exchange Capacity.
 - m. Carbonates Determination.
 - n. Soil Bulk Density.
 - o. Water Infiltration Rate per USDA Handbook No. 60, Method 34b.
3. At least 30 days prior to commencement of soil preparation Work, submit to the Architect/Engineer and Horticultural Consultant the laboratory's written soil test report including the laboratory's soil test data; the laboratory's interpretation of nutritional deficiencies, excesses, and potential toxicities; the laboratory's amendment recommendations; and the laboratory's maintenance recommendations.
 4. The Architect/Engineer and Horticultural Consultant will determine the final amendment and maintenance period fertilization programs based on the soil test report which may differ from the soil test report amendment recommendations.

F. Soil Tests for Parasitic Nematodes:

1. Test soils which have been used for agricultural purposes within the prior 12 months for parasitic nematodes.
2. Soil will be acceptable if the parasitic nematode population is less than 200 per 50 cubic centimeters of soil.
3. Do not artificially dry soil prior to testing.
4. Submit written test report to the Architect/Engineer and Horticultural Consultant.

G. Soil Tests for Herbicide Contamination:

1. Perform a radish/rye grass growth trial on soils suspected of herbicide contamination.
2. Submit written test report to the Architect/Engineer and Horticultural Consultant.

3.2 WEED ERADICATION PROGRAM OF EXISTING VEGETATION AT PLANTING AREAS

- A. Six weeks prior to planting and before tilling or amending planting areas, spray existing vegetation with 3 percent Glyphosate solution and repeat treatment 3 weeks later to kill re-emerging vegetation.

3.3 PREPARATION OF IN-PLACE PLANTING AREAS

A. Protection:

1. Use every possible precaution to prevent damage to existing conditions to remain such as structures, utilities, irrigation systems, plant materials and paving on or adjacent to the site of the Work.
2. Use every possible precaution to prevent excessive compaction of planting area soil within or adjacent to the areas of Work.
3. Provide barricades, fences or other barriers to protect existing conditions to remain from damage and excessive compaction during construction.
4. Do not store materials or equipment, permit burning, or operate or park equipment under the branches of existing plants to remain.
5. Submit written notification of conditions damaged during construction to the Owner's Designated Representative immediately.

B. Tilling: Broadcast amendments, uniformly till soil surface to a 6 to 8-inch depth using a rototiller or other accepted tilling implement.

C. Cleaning Soil Surface: After tilling soil surface, clear soil surface of surface stones larger than 1 inch, debris, roots, branches, sticks, contaminated soil, and other extraneous materials.

3.4 PREPARATION OF SUBGRADE TO RECEIVE IMPORTED SOIL MIXES

A. Protection:

1. Use every possible precaution to prevent damage to existing conditions to remain such as structures, utilities, irrigation systems, plant materials and paving on or adjacent to the site of the Work.
2. Use every possible precaution to prevent excessive compaction of planting area soil within or adjacent to the areas of Work.
3. Provide barricades, fences or other barriers to protect existing conditions to remain from damage and excessive compaction during construction.
4. Do not store materials or equipment, permit burning, or operate or park equipment under the branches of existing plants to remain.

- B. Submit written notification of conditions damaged during construction to the Owner's Designated Representative immediately. Ripping Subgrade Soil:
1. Prior to placing topsoil, rip areas to receive topsoil on the same day topsoil is placed.
 2. Rip subgrade twice to a depth of 6 inches unless indicated otherwise.
 3. Space ripping tines at 24 inches on center.
 4. Make second ripping pass in a direction 90 degrees to the direction of the first ripping pass.
 5. Do not rip closer than 2 feet horizontally and vertically to installed and existing utility lines and structures.
- C. Topsoil Placement:
1. Place topsoil same day that subgrade soil ripping occurs and prior to vehicle or equipment traffic running over the ripped surface.
 2. Place topsoil with equipment of appropriate size for area and in a manner that avoids excessive compaction of the topsoil.
 3. Avoid repeatedly driving equipment in same tracks so that topsoil does not become excessively compacted.
- D. Allowances: Place topsoil to elevations that allow for settlement, addition of soil amendment, and finish grading tolerances.
- E. Topsoil Finished Grade: See Section 32 91 19.
- F. Surface Drainage: Keep topsoil surface sloped so that surface drains.
- G. Compaction and Contamination:
1. In handling materials and operating tools and equipment, protect the topsoil from excessive compaction by laying down planks, plywood, or other accepted protective devices.
 2. Do not store or stockpile materials on the topsoil.
 3. Do not allow vehicles to park or drive on topsoil, except equipment which is preparing and finish grading the soil.
 4. If ruts are formed, blade rutted topsoil smooth.
 5. Loosen excessively compacted soil to the full depth of the excessive compaction, rototill, and grade surface smooth.
- H. Excessively Compacted Topsoil:
1. Mechanically loosen excessively compacted topsoil to its full depth via a method acceptable to the

Landscape Architect and re-grade surface smooth.

2. Keep topsoil from being excessively compacted until date of Final Completion.

I. Erosion Repair:

1. Repair erosion that occurs between topsoil installation and plant or seed installation.
2. Fill eroded areas with topsoil and finish grade.

3.5 PREPARATION OF SOIL SURFACE OF PLANTING AREAS

A. Protection of Existing Conditions:

1. Use every possible precaution to prevent damage to existing conditions to remain such as structures, utilities, plant materials and walks on or adjacent to the site of the Work.
2. Use every possible precaution to prevent excessive compaction of planting area soil within or adjacent to the areas of Work.
3. Provide barricades, fences or other barriers to protect existing conditions to remain from damage during construction.
4. Do not store materials or equipment, permit burning, or operate or park equipment under the branches of existing plants to remain.
5. Submit written notification of damaged plants and structures to the Owner's Designated Representative immediately.

B. Surface Preparation:

1. Inspect soil surface for sticks, oils, chemicals, plaster, concrete, and other deleterious materials.
2. Do Work required to remove and dispose of the deleterious materials.

C. Excessively Compacted Areas:

1. Where tilled planting soil or imported planting soils have become compacted more than 75-percent maximum dry density per ASTM D 1557 rip soil to 4 inches below the depth of the excessive compaction.

3.6 Space ripping tines at 18 inches on center. AMENDMENT OF SOIL SURFACE OF PLANTING AREAS

A. Preliminary Amendment Program to Establish Bid for Planting Areas to, Except Areas within Drip Lines of Existing Trees to Remain: 6 cubic yards of organic amendment per 1,000 square feet; 25 pounds polymeric soil conditioner per 1,000 square feet; 20 pounds of granular Micromax per 1,000 square feet; 5 pounds of Triple Superphosphate 0-45-0 per 1,000 square feet, and 18 pounds of Nitroform 38-0-0 per 1,000 square feet.

B. Preliminary Amendment Program to Establish Bid for Areas Within Drip Lines of Existing Trees to

Remain in Planting Areas: 3 cubic yards of organic amendment per 1,000 square feet, 10 pounds of polymeric soil conditioner per 1,000 square feet, 10 pounds of granular Micromax per 1,000 square feet, 9 pounds of Nitroform 38-0-0 per thousand square feet, and 2.5 pounds of Triple Superphosphate 0-45-0 per thousand square feet.

C. Final Amendment Programs for Installation: Determined by Architect/Engineer and Horticultural Consultant based on soil test report results.

D. Amendment Incorporation:

1. Spread dry amendments evenly over surface of dry soil with a drop spreader.
2. Organic amendment and soil must be dry.
3. Incorporate amendments uniformly within top 6 to 8 inches of soil within a few hours after amendment application, except at areas within drip lines of existing trees to remain.
4. At areas within drip lines of existing trees to remain, incorporate amendments uniformly to 1 to 2-inch depth within a few hours after application.
5. Mechanically incorporate the amendments into the soil via a method that will not excessively compact the soil below incorporated amendments.
6. To activate polymeric conditioner, irrigate soil very slowly so that soil surface will not form a crust and until water penetrates 6-inch depth.
7. Allow soil to dry until stringiness disappears.
8. Prior to planting, re-till soil to a 6-inch depth at areas outside of drip lines of existing trees to remain and re-till soil to a 1 to 2-inch depth at areas within drip lines of existing trees to remain.

3.7 FIELD QUALITY CONTROL

A. Soil Amendment Verification:

1. Schedule Horticultural Consultant to take up to 20 random composite samples of amended soil surface areas and soil mixes for laboratory testing to verify amendment composition.
2. Submit composite samples collected by the Horticultural Consultant to the same soil testing laboratory used to test the soil as indicated in Article 3.1 E of this Section.
3. Employ the laboratory to test soil samples and submit test results to Horticultural Consultant and

Architect/Engineer.

4. Perform corrective work as recommended by the laboratory soil test reports if directed to do so by the Architect/Engineer.
5. When a laboratory soil test indicates that the soil or soil mixes meet the requirements of the Specifications the Contractor will receive written notification of acceptance from the Architect/Engineer.
6. Installation of ground cover plants and seed may commence upon Contractor's receipt of the written notification of acceptance.

END OF SECTION

SECTION 32 92 23 - LAWN SODDING

PART 1 GENERAL

1.1 SUMMARY

- A. Section Includes: Sodding of Lawn Areas.
- B. Related Sections:
 - 1. Section 32 01 90, Landscape Maintenance Period.
 - 2. Section 32 91 13, Planting Soil Preparation.
 - 3. Section 32 91 19, Finish Grading.

1.2 REFERENCES

- A. ASTM — ASTM International: D 1557 — Test Method for Laboratory Compaction Characteristics of Soil Using Modified Effort.

1.3 DEFINITIONS

- A. Acceptance, Acceptable, or Accepted: Acceptance by the Landscape Architect in writing.
- B. Excessive Compaction: Planting area soil compaction greater than 75 percent maximum dry density as determined by ASTM D 1557.
- C. Landscape Architect: Landscape Architect employed by the Owner to provide professional landscape architectural services for the Project.

1.4 SUBMITTALS

- A. General Requirements: Refer to Division 1.
- B. Product Data: Sod.

1.5 QUALITY ASSURANCE

- A. Regulatory Requirements: Provide for inspections and permits required by federal, state and local authorities in furnishing, transporting, and installing materials.

1.6 PRODUCT DELIVERY, STORAGE AND HANDLING

- A. Harvest and Delivery of Sod:
 - 1. Harvest from the source and deliver to project site within 24 hours.
 - 2. Deliver only as much sod as can be installed within 24 hours after harvest.
 - 3. Sod not transplanted within 24 hours after harvest will be rejected.
- B. Storage and Protection: Protect sod which cannot immediately be laid by storing in shade and keeping it fresh with moistened burlap.

1.7 SEQUENCING AND SCHEDULING

- A. Sodding: Install sod after substantial completion of other trades,, fine grading approval, irrigation system coverage test and acceptance and shrub planting.

1.8 WARRANTY

- A. Warranty Period: Warrant that grasses shall be in a healthy and flourishing condition of active growth at the end of the next growing season after the date of Final Completion.
- B. Condition: Free of dead or dying patches, and areas shall show foliage of normal density, size and color.
- C. Delays: Delays in completion of planting operations which extend the planting into more than one planting season shall extend the Warranty period correspondingly.
- D. Coverage: Warrant growth and coverage of sod to the effect that a minimum of 95 percent of the area sodded shall be covered with specified planting after one growing season with no bare spots greater than 1 square foot.
- E. Replacement: As soon as weather conditions permit, resod, without additional cost to the Owner, areas of dead sod not in a vigorous, thriving condition, during and at the end of the Warranty Period.
- F. Requirements for Replacements: Apply requirements of this Section to replacement Work.

1.9 MAINTENANCE

- A. Maintenance Service: Refer to Section 32 01 90.

PART 2 PRODUCTS

2.1 MATERIALS

- A. PHC Turf Saver Fertilizer:
 - 1. Mycorrhizal fungicide inoculant formulated for turf installation and maintenance.
 - 2. Blend of mycorrhizal fungi and rhizosphere bacteria selected for beneficial activities in plants.

3. Colonize is a proprietary stimulant to increase colonization rates of grass roots.
4. Increases feeder root absorption capacity.
5. Prevents sod loss due to heat and drought stress.
6. Prevents root system decline.
7. Helps recover from stress and root damage.

B. Sod Type

1. Dark green in color, relatively free of thatch, free from diseases, weeds and harmful insects.
2. Reasonably free of objectionable grassy and broadleaf weeds. Sod will be considered weed free if no more than ten such weeds are found per hundred square feet of sod.
3. Free of Bermuda grass, quackgrass, johnsongrass, poison ivy, nimbleweed, thistle, bindweed, bentgrass, perennial sorrel, bromegrass.
4. Soil depth of 1/2-inch plus or minus 1/8-inch.
5. Strong enough that handling will not tear sod.

PART 3 EXECUTION

3.1 EXAMINATION

- A. General: Examine site and verify that conditions are suitable to receive Work and that no defects or errors are present which would cause defective installation of products or cause latent defects in workmanship and function.
- B. Finish Grade and Soil Preparation Verification: Verify finish grading and soil preparation Work is complete.

3.2 PREPARATION

- A. Protection of Existing Conditions:
1. Use adequate precautions to prevent damage to existing conditions to remain such as structures, utilities, plant materials and walks on or adjacent to the site of the Work.
 2. Use every possible precaution to prevent excessive compaction of planting area soil within or adjacent to the areas of Work.
 3. Provide barricades, fences or other barriers to protect existing conditions to remain from damage during construction.
 4. Do not store materials or equipment, permit burning, or operate or park equipment under the branches of existing plants to remain.
 5. Submit written notification of damaged plants and structures to the Owner's Designated Representative immediately.
- B. Soil Surface Preparation: Prior to installing sod, manually remove and dispose of rocks and clods larger than 1/2-inch diameter from soil surface using rakes and apply 22 pounds of PHC Turf Saver per 1,000 square feet.

3.3 SODDING

- A. Timing:
 - 1. Install sod within 24 hours of delivery.
 - 2. Sod not transplanted within 24 hours of delivery will be rejected.
- B. Rolling Sod Bed:
 - 1. Roll amended soil in lawn areas with 200-pound water-ballast roller.
 - 2. Tamp surfaces of lawn joint planting soil mix firm, to level indicated on the Drawings.
- C. Moistening Sod Bed: After unevenness in the soil surface has been corrected, lightly moisten the soil immediately prior to laying the sod.
- D. Handling Sod:
 - 1. Handle sod gently enough to avoid stretching or tearing pieces.
 - 2. Carry sod pieces rolled or folded.
 - 3. Do not carry sod pieces by one end.
- E. Laying Sod:
 - 1. Lay the first row of sod in a straight line, with subsequent rows parallel to and tightly against each other, with no spaces between strips.
 - 2. Stagger joints so none of the adjacent pieces align.
 - 3. Do not stretch or overlap sod.
 - 4. Butt joints tightly to eliminate gaps without stretching sod.
 - 5. Use a sharp knife to cut sod to fit angles and curves.
 - 6. Avoid installing small sod strips at edges.
 - 7. Water completed sections lightly during installation to keep moist before post installation irrigation of entire area.
 - 8. Do not repeatedly walk or kneel directly on sod during installation to avoid indentations and air pockets.
 - 9. When necessary to walk on sod during installation, lay down minimum 3/4-inch thick plywood to protect areas to be walked on.
 - 10. Remove protection plywood as soon as possible to avoid smothering sod.
- F. Tamping and Rolling Sod:
 - 1. Thoroughly tamp and roll sod with a 200-pound water-ballast roller to make contact with sod bed.
 - 2. Roll each entire section of completed sod.
- G. Watering: Thoroughly water sod immediately after installation to wet the underside of the new sod pad and the soil immediately below to a depth of 6 inches.

3.4 PROTECTION

- A. Sod Damage and Excessive Compaction:
 - 1. Restrict vehicular and foot traffic from new sod for 4 weeks after installation.
 - 2. After 4 weeks, do not allow equipment, vehicular, or foot traffic on sodded areas, except for lawn mowers and landscape maintenance personnel.

END OF SECTION

SECTION 033013 - LANDSCAPE CAST-IN-PLACE CONCRETE

PART 1 - GENERAL

1.1 RELATED DOCUMENTS

- A. Drawings and general provisions of the Contract, including General and Supplementary Conditions and Division 01 Specification Sections, apply to this Section.

1.2 SUMMARY

- A. Section includes decorative concrete paving and decorative walls.
- B. Related Sections:
 - 1. Section 03 30 00 "Cast-in-Place Concrete" for general building applications of concrete.
 - 2. Section 07 92 00 "Joint Sealants" for joint sealants in expansion and contraction joints within decorative concrete paving and walls and in joints between decorative concrete paving and walls and asphalt paving and walls or adjacent construction.

1.3 SUBMITTALS

- A. See section 01 30 00 – Administrative Requirements, for submittal procedures.
- B. Product Data:
 - 1. For each type of product indicated submit manufacturer's product data, specifications, typical installation details and other data to demonstrate compliance with the specified requirements for all manufacturer products.
 - 2. Statement of Mix Design: Submit (3) copies of Statement of Mix Design prepared by batch plant servicing Project for each load delivered to Project. Statement of Mix Design to contain following information:
 - a. Name, address, and telephone number of batch plant preparing statement of mix design.
 - b. Date of mix design.
 - c. Project location.
 - d. Contractor requesting load delivery.
 - e. Mix design number.
 - f. Integral color used.
 - g. Gradations for sand and aggregate.
 - h. Material weights, specific gravity, and absolute volumes.
 - i. Basis of testing, i.e. UBC 2605 D4 and Title 24 2604 D4.
 - j. Water/cement ratio.
 - k. PSI rating.
 - l. Signature of testing laboratory manager.
 - m. Signed stamp from registered Project structural engineer or architect LEED Submittals:
- C. Samples for Verification: To be determined by the mock-ups.

D. Shop Drawings:

1. Submit shop drawings for reinforcing steel and accessories in accordance with ACI standards.
2. Paving and walls Jointing and Pour Sequence Plan - submit three full size bond prints of each paving and walls sheet indicating the following:
 - a. Proposed layout of contraction, construction and isolation joints. Clearly delineate the three different joint types.
 - b. Layout of paving and walls types as indicated on Drawing Paving and walls Schedule. Give overall dimensions of each paving and walls type.
 - c. Concrete pour sequence. Indicated sequence of paving and walls pour installation.

1.4 DEFINITIONS

- A. Cementitious Materials: Portland cement alone or in combination with one or more of blended hydraulic cement, fly ash and other pozzolans, and ground granulated blast-furnace slag.

1.5 INFORMATIONAL SUBMITTALS

- A. Qualification Data: For qualified Installer.
- B. Material Certificates and Product Data: For the following, from manufacturer:
 1. Cementitious materials.
 2. Steel reinforcement and reinforcement accessories.
 3. Fiber reinforcement.
 4. Admixtures.
 5. Curing compounds.
 6. Applied finish materials.
 7. Bonding agent or epoxy adhesive.
 8. Joint fillers.

1.6 QUALITY ASSURANCE

- A. Installer Qualifications: A firm and individuals trained and approved by manufacturer of decorative concrete paving and walls systems with a minimum of fifteen consecutive years' experience. Provide written evidence to indicate successful experience in installing Intecrete, Lithocrete or equivalent architectural concrete paving and walls, or similar, on at least (5) projects with a combined installed square footage of at least 75,000 SF with (3) projects located within a 100 mile radius of Project site.
- B. ACI Certified Personnel:
 1. Concrete Flatwork Finisher:
 - a. Minimum of 1,500 hours of field experience having installed at least (5) projects containing decorative or equivalent architectural concrete paving and walls.
 - b. Must be present during important stages of concrete production such as layout, formwork, or concrete placement and finishing.
 - c. Project must have a minimum of (1) ACI certified Concrete Flatwork Finisher at important phases of production.
 - d. Submit verification of current ACI certification.

2. Concrete Flatwork Technician:
 - a. Minimum of (1) ACI certified Concrete Flatwork Technician able to render technical assistance on project, if requested.
 - b. Submit verification of current ACI certification.
- C. Ready-Mix-Concrete Manufacturer Qualifications: A firm experienced in manufacturing ready-mixed concrete products and that complies with ASTM C 94/C 94M requirements for production facilities and equipment.
 1. Manufacturer certified according to NRMCA's "Certification of Ready Mixed Concrete Production Facilities" (Quality Control Manual - Section 3, "Plant Certification Checklist").
- D. Testing Agency Qualifications: Qualified according to ASTM C 1077 and ASTM E 329 for testing indicated.
 1. Personnel conducting field tests shall be qualified as ACI Concrete Field Testing Technician, Grade 1, according to ACI CP-1 or an equivalent certification program.
- E. Source Limitations: Obtain decorative concrete paving and walls products and each type or class of cementitious material of the same brand from same manufacturer's plant, and obtain each aggregate from single source.
- F. Concrete Testing Service: Engage a qualified testing agency to perform material evaluation tests and to design concrete mixtures.
- G. ACI Publications: Comply with ACI 301 (ACI 301M) unless otherwise indicated.
- H. Mockups:
 1. Prepare on-site paving and walls mock-ups as follows:
 - a. Prepare a minimum 8-foot square mock-up of each different paving and walls type specified on Drawings. Label mock-ups (preferably on vertical side of mock-up) with specified paving and walls type to facilitate mock-up review.
 - b. Construct mock-ups using identical concrete mix design, products, jointing, and methods of overall workmanship that will be employed during production.
 - c. Ensure that same crew preparing mock-ups will be responsible for production work.
 - d. Construct mock-ups in a protected location approved by Owner. Ideally mock-ups should be located as close to production work as possible to facilitate comparison review and be located in a sunny location.
 - e. Approved mock-ups will be used as standard for future production work review and assessment. Owner should be prepared to physically sign mock-up using a permanent black marker to attest Owner's approval of mock-up. Rejected mock-ups can remain on-site until removal of approved mock-ups is required.
 - f. Original 6-inch or 12-inch concrete samples, if they were prepared for this project, will not be used in future production paving and walls review once mock-ups have been approved.
 - g. Owner will incur costs to redo mock-ups if Owner requires design changes during mock-up review. Contractor will incur costs to redo mock-ups if Owner rejects mock-ups due to Contractor error such as incorrect concrete mix design or unacceptable appearance.
 - h. Protect approved mock-ups from damage during course of Work.
 - i. Clean mock-ups prior to Final Walkthrough for Acceptance to facilitate unencumbered comparison review by Owner between approved mock-ups and production work.

- k. Remove mock-ups from site when directed by Owner.
- 2. Prepare retardant finish wall mock-ups as follows:
 - a. Minimum 5-foot long mock-up of each specific smooth Wall type indicated on Drawings.
 - b. Construct mock-ups using products, materials and workmanship methods identical to those that will be employed during production. Workmanship to exhibit finish, jointing, and edging. Use same concrete mix that will be used during production.
 - c. Ensure that same personnel that prepared mock-ups will also install production work.
 - d. Construct mock-ups in a location approved by General Contractor.
 - e. Approved wall mock-ups will be standard for assessment for future production work.
 - f. Construct additional mock-ups at smooth finish Contractor's expense if workmanship is responsible for mock-up rejection by Owner, however, Owner will incur costs to redo mock-up if Owner requests design changes during mock-up preparation.
 - g. Protect approved mock-ups during course of Work.
 - h. Remove mock-ups from site when directed by General Contractor.
- I. Preinstallation Conference: Conduct conference at Project site.
 - 1. At least three weeks prior to ordering specified materials or the start of concrete work, Arrange a pre-installation meeting between the Contractor, Architect, Project superintendent, concrete supplier, and concrete finisher to review finishing techniques of Concrete, use of additives, application of curing compounds and coordination with other trades.

1.7 PROJECT CONDITIONS

- A. Traffic Control: Maintain access for vehicular and pedestrian traffic as required for other construction activities.

PART 2 - PRODUCTS

2.1 FORMS

- A. Straight Sections:
 - 1. Depth of forms to be same depth as concrete being placed.
 - 2. Form work to be new lumber or re-used lumber that has been cleaned of residual concrete and laitance. Treat new or re-used form work with Wood Form Release prior to placing concrete.
- B. Curved Sections:
 - 1. Use 1 ½-inch bender or back-cut boards or 1/2-inch wood siding, installed with sufficient bracing for construction of curved formwork.
- C. Plywood:
 - 1. Exterior grade plywood panels, non-absorptive, providing a continuous, true, and smooth surface such as medium-density overlay (MDO), Class 1, or better, with mill-applied release agent and sealed edges.
 - 2. Form Joint Tape: Pressure-sensitive compressible foam tape.
 - 3. Form-Release Agent: Colorless form-release agent that will not bond with concrete surface or impair subsequent treatments of those surfaces.
- D. Structural:
 - 1. #2 Construction Grade S4S Douglas Fir minimum 1-1/2-inches thick, free of warping, loose knots,

cupping, checks, bows, cracks, and other imperfections that would produce objectionable defects in finished work.

2. Depth of forms to be same depth as concrete being placed.

2.2 STEEL REINFORCEMENT

- A. Reinforcing Bars: ASTM A 615/A 615M, Grade 60 (Grade 420); deformed.
- B. Plain-Steel Wire: ASTM A 82/A 82M.
- C. Joint Dowel Baskets: Pre-manufactured dowel basket assembly to provide construction joint stability, eliminate tripping hazards, positive load transfer, maintain continuity of surface profile, reduce joint spalling, and reduce “checkerboard” pours, without prohibiting horizontal slab movement.
 1. PD3 Basket Assembly® by PNA Construction Technologies; www.pna-inc.com.
 2. PNA Square/Round Dowel Basket Assembly by PNA Construction Technologies; www.pna-inc.com
- D. Bar Supports: Bolsters, chairs, spacers, and other devices for spacing, supporting, and fastening reinforcing bars, welded wire reinforcement, and dowels in place. Manufacture bar supports according to CRSI's "Manual of Standard Practice" from steel wire, plastic, or precast concrete of greater compressive strength than concrete specified.
- E. Steel Slip Dowels: 5/8-inch-diameter smooth steel bars, free of dirt, grease, and oils.
- F. Plastic Dowel Sleeves: Encase 50 percent of each dowel in a Speed Dowel plastic alignment sleeve to allow parallel lateral movement of each dowel.
 1. Acceptable Manufacturers:
 - a. Speed Dowel □ by Greenstreak Group; www.greenstreak.com.
 - b. Or approved substitution

2.3 CONCRETE MATERIALS

- A. Cementitious Material: Use the following cementitious materials, of the same type, brand, and source, throughout Project:
 1. Portland Cement: ASTM C 150, gray portland cement Type III or Type V. Supplement with the following:
 - a. Fly Ash: ASTM C 618, Class C or F.
 - b. Ground Granulated Blast-Furnace Slag: ASTM C 989, Grade 100 or 120.
- B. Normal-Weight Aggregates: ASTM C 33, Class 4S uniformly graded. Provide aggregates from a single source.
 1. Maximum Aggregate Size: 1 inch (25 mm) nominal.
 2. Fine Aggregate: Free of materials with deleterious reactivity to alkali in cement.
- C. Water: Potable and complying with ASTM C 94/C 94M.
- D. Air-Entraining Admixture: ASTM C 260.

- E. Chemical Admixtures: Admixtures certified by manufacturer to be compatible with other admixtures and to contain no more than 0.1 percent water-soluble chloride ions by mass of cementitious material.
 - 1. Water-Reducing Admixture: ASTM C 494/C 494M, Type A.
 - 2. Water-Reducing and Retarding Admixture: ASTM C 494/C 494M, Type D.
 - 3. Water-Reducing and Accelerating Admixture: ASTM C 494/C 494M, Type E.
- F. Liquid Color Pigment: ASTM C 979, synthetic mineral-oxide pigments or colored water-reducing admixtures; color stable, nonfading, and resistant to lime and other alkalis.
 - 1. Manufacturers: Subject to compliance with requirements, provide products by one of the following:
 - a. Davis Colors.
 - b. Admixtures Inc.
 - c. Scofield, L. M. Company.
 - d. Solomon Colors, Inc.

2.4 FIBER REINFORCEMENT

- A. Synthetic Fiber: Monofilament polypropylene fibers engineered and designed for use in decorative concrete paving and walls, complying with ASTM C 1116/C 1116M, Type III, 1/4" inch (6 mm long).
 - 1. Products: Subject to compliance with requirements, provide one of the following:
 - a. Monofilament Fibers:
 - 1) Grace, W. R. & Co. - Conn.; Grace MicroFiber.
 - 2) Propex Fibermesh: Fibermix Stealth.

2.5 CURING AND SEALING MATERIALS

- A. Amber, Aliphatic, Membrane-Forming Curing and Sealing Compound; manufactured for use with colored concrete.
 - 1. Products: Admixtures Inc; Colorfull Clear Curing Compound
- B. Sealant:
 - 1. Two component, non-sag, polyurethane sealant.
- C. Acceptable Manufacturer's:
 - 1. Dynatrol® II by Pecora Corp; www.pecora.com.
 - 2. Sikaflex® 2c NS by Sika Corporation; www.sikausa.com.
 - 3. Dymeric® 240 by Tremco; www.tremcosealants.com.

2.6 RELATED MATERIALS

- A. Fine and Coarse Aggregate: Clean, hard, and durable washed concrete sand conforming to ASTM C33. Use same fine aggregate from single source throughout duration of Project. Refer to Paving and walls Schedule on Drawings for sizing of coarse aggregate. Some paving and walls types may require different coarse aggregate sizes
- B. Joint Fillers: ASTM D 5249, Type 2, flexible foam expansion joint in preformed strips.

1. Products: W.R. Meadows; Seal Tight Cermar.
- C. Chemical Surface Retarder: Water-soluble, liquid, set retarder with color dye, for horizontal concrete surface application, capable of temporarily delaying final hardening of concrete to a depth of 1/8 to 1/4 inch (3 to 6 mm).
1. Products: ACC; Optimus
- D. Concrete Admixture Modifiers:
1. Set Accelerators:
 - a. Admixture designed to facilitate placement of concrete during cold weather conditions or to provide additional placement time resulting in shortened set time and increased early age PSI strength conforming to ASTM C494/C494M Type C.
 - b. Acceptable Manufacturers:
 - 1) MasterSet® AC 122 by BASF; www.master-builders-solutions.basf.us/en-us.
 - 2) Accelguard® 80 by Euclid Chemical Company; www.euclidchemical.com.
 - 3) Polarsset® by Grace; www.grace.com.
 - 4) Plastocrete® 161FL by Sika; www.usa.sika.com.
- E. Set Retarders:
1. Admixture designed to control concrete set times during hot weather conditions or to extend concrete delivery times. Conforms to ASTM C494/C494M, Type D.
 2. Acceptable Manufacturers:
 - a. MasterSet® R 122 by BASF; www.master-builders-solutions.basf.us/en-us.
 - b. Eucon HC® by Euclid Chemical Company; www.euclidchemical.com.
 - c. Recover® by Grace; www.grace.com.
 - d. Plasitment® by Sika; www.usa.sika.com.
- F. Water Reducers:
1. Admixture designed to lower water content in order to achieve greater plasticity, facilitate handling and workability, increase compressive strength, permeability and durability, while reducing aggregate segregation and slab cracking. Conforms to ASTM C494/C494M Type A and D.
 2. Acceptable Manufacturers:
 - a. MasterPozzolith® 80 by BASF; www.master-builders-solutions.basf.us/en-us.
 - b. Eucon NW™ by Euclid Chemical Company; www.euclidchemical.com.
 - c. WRDA® 64 by Grace; www.grace.com.
 - d. Plastocrete-10N by Sika; www.usa.sika.com.
- G. Shrinkage Reducers:
1. Admixture that reduces slab shrinkage, micro cracking, and edge curling while increasing impermeability and durability.
 2. Acceptable Manufacturers:
 - a. MasterLIFE® SRA 20 by BASF; www.master-builders-solutions.basf.us/en-us.
 - b. Eucon SRA+™ by Euclid Chemical Company; www.euclidchemical.com.
 - c. Eclipse® Floor 200 by Grace; www.grace.com.
 - d. Sika® Control 40 by Sika; www.usa.sika.com.

2.7 CONCRETE MIXTURES

- A. Prepare design mixtures, proportioned according to ACI 301 (ACI 301M), for each type and strength of normal-weight concrete, and as determined by either laboratory trial mixtures or field experience.
 - 1. Use a qualified independent testing agency for preparing and reporting proposed concrete design mixtures for the trial batch method.
- B. Proportion mixtures to provide normal-weight concrete with the following properties:
 - 1. Compressive Strength (28 Days): 3000 psi.
 - 2. Maximum Water-Cementitious Materials Ratio at Point of Placement: 0.50.
 - 3. Slump Limit: 5 inches (125 mm). plus or minus 1 inch (25 mm).
- C. Add air-entraining admixture at manufacturer's prescribed rate to result in normal-weight concrete at point of placement having an air content as follows:
 - 1. Air Content: 5 percent plus or minus 1.5 percent for 3/4-inch (19-mm) nominal maximum aggregate size.
- D. Chemical Admixtures: Use admixtures according to manufacturer's written instructions.
 - 1. Use water-reducing and retarding admixture in concrete as required for placement and workability.
- E. Synthetic Fiber: Uniformly disperse in concrete mixture at manufacturer's recommended rate, but not less than 1.0 lb/cu. yd. (0.60 kg/cu. M)
- F. Color Pigment: Add color pigment to concrete mixture according to manufacturer's written instructions and to result in hardened concrete color consistent with approved mockup.

2.8 CONCRETE MIXING

- A. Ready-Mixed Concrete: Measure, batch, and mix concrete materials and concrete according to ASTM C 94/C 94M. Furnish batch certificates for each batch discharged and used in the Work.
 - 1. When air temperature is between 85 and 90 deg F (30 and 32 deg C), reduce mixing and delivery time from 1-1/2 hours to 75 minutes; when air temperature is above 90 deg F (32 deg C), reduce mixing and delivery time to 60 minutes.

PART 3 - EXECUTION

3.1 SUBGRADE PREPARATION

- A. Prior to placing concrete on subgrade confirm with responsible party that:
 - 1. Subgrade is in conformance with requirements contained in Project's geotechnical soils report and Drawings.
 - 2. Subgrade is free of compressible or expansive soils, exposed rocks, loose soil, and debris.
 - 3. Subgrade has positive drainage and extends 12-inches beyond outside edge of paving and walls.
 - 4. Subgrade is within 1/10th-foot of paving and walls finish surface grades.
 - 5. Subgrade pre-saturation has been performed and resulting data meets Project geotechnical engineer's approval prior to placing concrete. Do not place concrete if subgrade is overly saturated.
 - 6. Utilities under paving and walls or in walls are in place and approved by Owner prior to placing concrete.
 - 7. Owner has approved subgrade and conditions noted above prior to placing of concrete.

- B. Moisten subgrade with an even spray prior to placing concrete to control initial loss of moisture from concrete slab. Do not place concrete over overly saturated subgrade.
- C. Remove loose material from compacted subbase surface immediately before placing concrete.

3.2 EXAMINATION

- A. Examine exposed subgrades and subbase surfaces for compliance with requirements for dimensional, grading, and elevation tolerances.
- B. Proof-roll prepared subbase surface below decorative concrete paving and walls to identify soft pockets and areas of excess yielding.
- C. Proceed with installation only after unsatisfactory conditions have been corrected.

3.3 PREPARATION

- A. Remove loose material from compacted subbase surface immediately before placing concrete.
- B. Protect adjacent construction from discoloration and spillage during application of color hardeners, release agents, stains, curing compounds, and sealers.

3.4 FORMWORK

- A. Set, brace, and secure edge forms, bulkheads, and intermediate screed guides to required lines, grades, and elevations. Install forms to allow continuous progress of work and so forms can remain in place at least 24 hours after concrete placement.
- B. Use new form lumber for the project that is new #2 or better grade wood.
- C. Contractor is responsible for design, engineering, and construction of formwork necessary to install its Work under this section.
- D. Review Drawings then provide necessary recesses and openings of proper sizes and shapes to accommodate required embeds. Secure anchor plates, inserts, and other items to be embedded in concrete as provided by others, accurately so that they will not be displaced during concrete placement.
- E. Coat plywood forms with form-release agent prior to concrete placement to ensure separation from concrete without damage to concrete.
- F. Install formwork using a digital electronic transit for formwork layout accuracy.
- G. Butt tight joints in forming materials and bear on solid construction. Carefully form bevels, grooves and recesses to form neat and straight lines.
- H. Set forms to meet alignment, shape, dimensions and grades as indicated on Drawings.
- I. Build temporary bulkheads and key as required. Securely brace at planned locations of construction joints.
- J. Construct straight formwork true, plumb with limited deviation.

- K. Space column clamps, wall ties, form hangers and other structural accessories for forms so that their working capacities are not exceeded by loads imposed by concrete and by concreting operations.
- L. Construct radial formwork concentric with smooth transitions to adjoining straight sections.
- M. Should misalignment of forms, excessive deflection of forms, or displacement of reinforcing occur during concrete placement, take corrective measures immediately, to extent, if necessary, that placing operations be stopped and concrete removed from within forms. Corrective measures to be such as to ensure acceptable lines and surfaces to required dimensions and cross sections.
- N. Notify Owner's Authorized Representative at least 48 hours in advance of completion of formwork and obtain Owner's Authorized Representative approval of formwork layout prior to concrete placement.
- O. Allow formwork to remain in place long enough for concrete to set properly. Remove formwork when appropriate and discard offsite
- P. Formwork to comply with ACI 347-01.
- Q. Construct formwork of sufficient thickness and joint tightness so deformation and concrete seepage will not occur during concrete placement. Hold formwork securely in-place with stakes, clamps, spreaders or braces to ensure formwork will be stable during concrete placement.
- R. Construct forms in such a manner that construction joints occur at locations indicated on Paving Jointing Plan.
- S. Clean forms after each use and coat with form-release agent to ensure separation from concrete without damage.

3.5 STEEL REINFORCEMENT

- A. General: Comply with CRSI's "Manual of Standard Practice" for fabricating, placing, and supporting reinforcement.
- B. Clean reinforcement of loose rust and mill scale, earth, ice, or other bond-reducing materials.
- C. Arrange, space, and securely tie bars and bar supports to hold reinforcement in position during concrete placement. Maintain minimum cover to reinforcement.
- D. Install welded wire reinforcement in lengths as long as practicable. Lap adjoining pieces at least one full mesh, and lace splices with wire. Offset laps of adjoining widths to prevent continuous laps in either direction.
- E. Install fabricated bar mats in lengths as long as practicable. Handle units to keep them flat and free of distortions. Straighten bends, kinks, and other irregularities, or replace units as required before placement. Set mats for a minimum 2-inch (50-mm) overlap to adjacent mats.

3.6 FORM TIES

- A. Exposed form ties will not be visible once the concrete wall is architecturally finished, however, form ties will still be required to construct wall.
- B. Internally disconnecting or removable ties designed to resist lateral pressure of fresh concrete on forms and to prevent spalling of concrete upon removal. Furnish internally disconnecting ties that will leave no

metal closer than 1-1/2-inches from the architectural concrete surface.

- C. Form ties to have a minimum working strength when fully assembled of at least 3,000 lbs.
- D. Adjust form ties in length so as to permit complete tightening of forms and of such type as to lean no metal closer than 1-inch to an exterior surface or closer than 1/2-inch to an interior surface.
- E. Do not fit form ties with lugs, cones, washers, or other device so as to act as a spreader within forms, or for other purposes that will leave a hole or depression larger than 7/8-inch in diameter back of exposed surface of concrete.
- F. Do not use wire or wood ties.
- G. Coat ties that are to be pulled from walls with cup grease or other approved material to facilitate efficient removal.
- H. Loosen tie rods that are to be entirely removed from walls 24 hours after concrete is poured. Remove all but a sufficient number of ties to hold forms in place

3.7 JOINTS

- A. General: Form construction, isolation, and contraction joints and tool edges true to line, with faces perpendicular to surface plane of concrete. Construct transverse joints at right angles to centerline unless otherwise indicated.
 - 1. When joining existing paving and walls, place transverse joints to align with previously placed joints unless otherwise indicated.
- B. Construction Joints: Set construction joints at side and end terminations of paving and walls and at locations where paving and walls operations are stopped for more than one-half hour unless paving and walls terminates at isolation joints.
 - 1. Continue steel reinforcement across construction joints unless otherwise indicated. Do not continue reinforcement through sides of paving and walls strips unless otherwise indicated.
 - 2. Dowelled Joints: Install dowel bars and support assemblies at joints where indicated. Lubricate or coat with asphalt one-half of dowel length to prevent concrete bonding to one side of joint.
- C. Expansion Joints: Form isolation joints of preformed joint-filler strips abutting concrete curbs, catch basins, manholes, inlets, structures, walks, other fixed objects, and where indicated.
 - 1. Locate expansion as indicated.
 - 2. Extend joint fillers full width and depth of joint.
 - 3. Terminate joint filler not less than 1/2 inch (13 mm) or more than 1 inch (25 mm) below finished surface if joint sealant is indicated.
 - 4. Place top of joint filler flush with finished concrete surface if joint sealant is not indicated.
 - 5. Furnish joint fillers in one-piece lengths. Where more than one length is required, lace or clip joint-filler sections together.
 - 6. During concrete placement, protect top edge of joint filler with metal, plastic, or other temporary preformed cap. Remove protective cap after concrete has been placed on both sides of joint.
- D. Sawed Joints: Form contraction joints with power saws equipped with shatterproof abrasive or diamond-rimmed blades. Cut 3/16-inch- (5-mm-) wide joints into concrete when cutting action will not tear, abrade, or otherwise damage surface and before developing random contraction cracks.

1. Perform jointing with a new diamond tip circular saw.
 2. Joint Width: Per Drawings. Do not exceed 3/16-inch in width.
 3. Depth of sawcuts: 1/4th depth of slab.
 4. Decorative Sawcut Joints: Per Drawings.
 5. Sawcut joints in a straight line with no overcutting.
 6. Use a hand tool to sawcut up to vertical edges such as walls, steps, curbs and columns. No cutting into vertical surfaces will be allowed.
- E. Edging: After initial floating, tool edges of paving and walls, gutters, curbs, and joints in concrete with an edging tool to a 1/4-inch (6-mm) radius. Repeat tooling of edges after applying surface finishes. Eliminate edging tool marks on concrete surfaces.

3.8 CONCRETE PLACEMENT

- A. Before placing concrete, inspect and complete formwork installation, steel reinforcement, and items to be embedded or cast-in.
- B. Moisten subbase to provide a uniform dampened condition at time concrete is placed. Do not place concrete around manholes or other structures until they are at required finish elevation and alignment.
- C. Comply with ACI 301 (ACI 301M) requirements for measuring, mixing, transporting, and placing concrete.
- D. Do not add water to concrete during delivery or at Project site. Do not add water to fresh concrete after testing.
- E. Deposit and spread concrete in a continuous operation between transverse joints. Do not push or drag concrete into place or use vibrators to move concrete into place.
- F. Consolidate concrete according to ACI 301 (ACI 301M) by mechanical vibrating equipment supplemented by hand spading, rodding, or tamping.
1. Consolidate concrete along face of forms and adjacent to transverse joints with an internal vibrator. Keep vibrator away from joint assemblies, reinforcement, or side forms. Use only square-faced shovels for hand spreading and consolidation. Consolidate with care to prevent dislocating reinforcement dowels and joint devices.
- G. Screed paving surface with a straightedge and strike off.
- H. Deposit concrete continuously or in layers of such thickness that no new concrete will be placed on concrete that has hardened sufficiently to cause seams or planes of weakness.
- I. If a section cannot be placed continuously, provide a construction joint.
- J. Screed top surface of wall with a straightedge then strike-off to meet specified top of wall elevations.
- K. After bleed water has evaporated, tool required top joints and edges and apply a surface finish as indicated on Drawings.
- L. If concrete is to be pumped instead of tailgating, protect adjacent paving or other improvements by supporting concrete pump hose and its metal connections on plywood, sand bags, or other suitable material.

- M. Consolidate concrete by mechanical vibration supplemented by hand spading, rodding, and tamping. Keep vibrator away from joint assemblies, reinforcement, or side forms. Use equipment and procedures to consolidate concrete complying with ACI 309R-05 – *Guide for Consolidation of Concrete*
- N. Commence initial floating using bull floats or darbies to impart an open-textured and uniform surface plane before excess moisture or bleed water appears on the surface. Do not further disturb concrete surfaces before beginning finishing operations or spreading surface treatments.
- O. Hot-Weather Placement: Comply with ACI 301 (ACI 301M) and as follows when hot-weather conditions exist:
 - 1. Cool ingredients before mixing to maintain concrete temperature below 90 deg F (32 deg C) at time of placement. Chilled mixing water or chopped ice may be used to control temperature, provided water equivalent of ice is calculated in total amount of mixing water. Using liquid nitrogen to cool concrete is Contractor's option.
 - 2. Fog-spray forms, steel reinforcement, and subgrade just before placing concrete. Keep subgrade moisture uniform without standing water, soft spots, or dry areas.

3.9 FLOAT FINISHING

- A. General: Do not add water to concrete surfaces during finishing operations.
- B. Float Finish: Begin the second floating operation when bleed-water sheen has disappeared, and concrete surface has stiffened sufficiently to permit operations. Float surface with power-driven floats or by hand floating if area is small or inaccessible to power units. Finish surfaces to true planes. Cut down high spots and fill low spots. Refloat surface immediately to uniform granular texture.
- C. Burlap Finish: Drag a seamless strip of damp burlap across float-finished concrete, perpendicular to line of traffic, to provide a uniform, gritty texture.
- D. Medium-to-Fine-Textured Broom Finish: Draw a soft-bristle broom across float-finished concrete surface, perpendicular to line of traffic, to provide a uniform, fine-line texture.
- E. Medium-to-Coarse-Textured Broom Finish: Provide a coarse finish by striating float-finished concrete surface 1/16 to 1/8 inch (1.6 to 3 mm) deep with a stiff-bristled broom, perpendicular to line of traffic.

3.10 INTEGRALLY COLORED CONCRETE FINISH

- A. Integrally Colored Concrete Finish; after final floating:
 - 1. Retardant Finish: Roll with roller tamper and then immediately bullfloat in both directions. Immediately after initial floating, towel smooth with no indentions, apply retardant when surface has sufficient moisture in the surface.
 - 2. Spray-apply chemical surface retarder to paving and walls according to manufacturer's written instructions.

3.11 REMOVAL OF WALL FORMWORK

- A. Remove formwork only when concrete is self-supporting but still allows for trowelling of surface. Timely removal of wall forms is essential in order to facilitate final finishing of SmoothCast™ wall.

3.12 CONCRETE PROTECTION AND CURING

- A. General: Protect freshly placed concrete from premature drying and excessive cold or hot temperatures.
- B. Begin curing after finishing concrete but not before and applying retardant finish.
- C. Curing and Sealing Compound: Apply uniformly in continuous operation by power spray or roller according to manufacturer's written instructions. Recoat areas subjected to heavy rainfall within three hours after initial application. Repeat process 24 hours later and apply a second coat. Maintain continuity of coating and repair damage during curing period.

3.13 PAVING AND WALLS TOLERANCES

- A. Comply with tolerances in ACI 117 and as follows:
 - 1. Elevation: 3/4 inch (19 mm).
 - 2. Thickness: Plus 3/8 inch (10 mm), minus 1/4 inch (6 mm).
 - 3. Surface: Gap below 10-foot- (3-m-) long, unlevelled straightedge not to exceed 1/8 inch (3 mm).
 - 4. Lateral Alignment and Spacing of Dowels: 1 inch (25 mm).
 - 5. Vertical Alignment of Dowels: 1/4 inch (6 mm).
 - 6. Alignment of Dowel-Bar End Relative to Line Perpendicular to Paving and walls Edge: 1/4 inch per 12 inches (6 mm per 300 mm) of dowel.
 - 7. Joint Spacing: 1/8 inches (3 mm).
 - 8. Contraction Joint Depth: Plus 1/4 inch (6 mm), no minus.
 - 9. Joint Width: 1/16 inches (1.5 mm).

3.14 FIELD QUALITY CONTROL

- A. Strength of each concrete mixture will be satisfactory if average of any three consecutive compressive-strength tests equals or exceeds specified compressive strength and no compressive-strength test value falls below specified compressive strength by more than 500 psi (3.4 MPa).
- B. Test results shall be reported in writing to Architect, concrete manufacturer, and Contractor within 48 hours of testing. Reports of compressive-strength tests shall contain Project identification name and number, date of concrete placement, name of concrete testing and inspecting agency, location of concrete batch in Work, design compressive strength at 28 days, concrete mixture proportions and materials, compressive breaking strength, and type of break for both 7- and 28-day tests.
- C. Decorative concrete will be considered defective if it does not pass tests and inspections.
- D. Additional testing and inspecting, at Contractor's expense, will be performed to determine compliance of replaced or additional work with specified requirements.

3.15 STAINING AND SEALING

- A. Allow Stratified or Sedimentary TM to dry sufficiently before applying specified stain or sealer.
- B. Do not apply sealer if air temperatures are below 50 degree F or above 90 degrees F.
- C. Once the concrete surface has been sealed, protect surface until fully dried.
- D. Follow manufacturer's directions for stain or sealer application.

3.16 REPAIRS AND PROTECTION

- A. Remove and replace decorative concrete that is broken or damaged or does not comply with requirements in this Section. Remove work in complete sections from joint to joint unless otherwise approved by Architect.
- B. Protect decorative concrete from damage. Exclude traffic from paving and walls for at least 14 days after placement. When construction traffic is permitted, maintain paving and walls as clean as possible by removing surface stains and spillage of materials as they occur.
- C. Maintain decorative concrete free of stains, discoloration, dirt, and other foreign material. Sweep paving and walls not more than two days before date scheduled for Substantial Completion inspections.

END OF SECTION 033013

SECTION 320190.13 – LANDSCAPE MAINTENANCE FOR 90 DAYS

PART 1 - GENERAL

1.1 SUMMARY

A. Section includes requirements for 90 day landscape maintenance for the following:

1. Watering trees and grass.
2. Monitoring adjustment and minor repair of the landscape irrigation system.
3. Mowing, edging and trimming of lawn areas.
4. Monitoring, fertilizing, weeding, and cultivating of lawn areas.
5. Pruning and trimming of plant material.
6. Weed, cultivating and cleaning of planting beds.
7. Application of fertilizers, insecticides, and herbicides.
8. General site clean up; removal of trash and products of maintenance.
9. Replacement of trees, shrubs, groundcovers, sod and hydromulch.
10. Sediment removal from bayou high water.
11. Extra services as needed.

B. Related Sections

1. Turfs and Grasses - Section 329200
2. Planting Irrigation Systems – Section 328400

1.2 DEFINITIONS

- A. Backfill: The earth used to replace or the act of replacing earth in an excavation.
- B. Finish Grade: Elevation of finished surface of planting soil.
- C. Manufactured Topsoil: Soil produced off-site by homogeneously blending mineral soils or sand with stabilized organic soil amendments to produce topsoil or planting soil.
- D. Planting Soil: Native or imported topsoil, manufactured topsoil, or surface soil modified to become topsoil; mixed with soil amendments.
- E. Subgrade: Surface or elevation of subsoil remaining after completing excavation, or top surface of a fill or backfill, before placing planting soil.
- F. Subsoil: All soil beneath the topsoil layer of the soil profile, and typified by the lack of organic matter and soil organisms.

1.3 EXTRA SERVICES

- A. All services not covered under this contract shall be considered "extra services" and will be charged for separately according to the nature of the item of work. The consent and authorization of the Owner or their authorized representative must be obtained prior to the performance or installation of such "extra services" items and prior to purchase of any chargeable materials.
- B. Plant replacements as a result of flood damage.

1.4 MAINTENANCE REQUIREMENTS

- A. Begin maintenance after each plant and lawn portion is installed.
- B. Maintenance period shall begin upon inspection and approval at Substantial Completion by phase and shall be for ninety (90) days.
- C. Sprinkler Irrigation System: Maintenance of the sprinkler irrigation system shall consist of monitoring and adjustment of the duration and frequency of the watering schedule, adjustment of heads for coverage and elevation, repair of leaks in both mains and lateral lines and all other work required to establish a complete working sprinkler irrigation system.
- D. Trees, Shrubs, Groundcovers and Vines: Maintenance of new planting shall consist of watering, cultivating, weeding, mulching, re-staking, tightening and repairing of guys, resetting plants to proper grades or upright position, restoration of the planting saucer, and furnishing and applying such sprays and invigorants as are necessary to keep the plantings free of insects and disease and in thriving condition.
- E. Lawns: Maintenance of new lawns shall consist of mowing, edging, raking, watering, weeding, fertilizing, and repair of all erosion reseeding, resodding, necessary to establish a uniform stand of the specified grasses.

1.5 PROTECTION

- A. Protect planting areas and lawns at all times against damage of all kinds for duration of maintenance period. Maintenance includes temporary protection fences, barriers and signs as required for protection. If any plants become damaged or injured, because sufficient protection was not provided, treat or replace as directed by Owner at no additional cost to Owner.

1.6 NEGLECT AND VANDALISM

- A. Turf, shrubs, trees or plants that are damaged or killed due to contractors operations, negligence or chemicals shall be replaced at no expense to the Owner. If plant damage or death is caused by conditions beyond the contractor's control, replacement shall be at the Owner's expense.

- B. Sprinklers or structures that are damaged due to the contractor's operations must be replaced by the contractor promptly. Likewise, damage to the irrigation system by others shall be corrected immediately by the contractor, at the Owner's expense.
- C. All man made water damage, resulting from Contractor's neglect shall be corrected at Contractor's expense.
- D. All damage to or thefts of landscaping and irrigation installations not caused or allowed by the contractor shall be corrected by the contractor at the Owner's expense upon receipt of written authorization to proceed.

1.7 EMERGENCIES

- A. Answer emergency or complaint calls regarding conditions in landscaped areas regarding fallen trees or branches or shrubs or trees that obstruct the trail or other pavement within 1 hour and correct the problem or place warning signs and advise the Owner of the need for major work to be performed within 4 hours of the initial contact.
- B. Answer emergency calls regarding the landscape irrigation system failure or need of repair.

1.8 FINAL ACCEPTANCE

- A. Work under this Section will be accepted by Owner's representative upon satisfactory completion of all work, including maintenance, but exclusive of the required guaranteed sprinkler irrigation obligations, replacement of plant materials and lawns under the Warranty Period. Upon Final Acceptance, the Owner will assume responsibility for maintenance of the work.

PART 2 - PRODUCTS

2.1 MATERIALS

- A. Materials required for installed items shall match those already in use.
- B. Samples of all materials not specified under other Sections of these Specifications shall be submitted for review by Owner's representative prior to use.

PART 3 - EXECUTION

3.1 REQUIRED EQUIPMENT

- A. Provide the necessary maintenance equipment.

3.2 WATERING

- A. It shall be the responsibility of the Contractor to assure that the correct watering of plant materials is being accomplished through the following irrigation services:
1. Regular deep watering to all new trees until there are definite signs that the trees have established themselves and new growth is apparent. Deep watering shall be accomplished with hoses and water truck equipment.
 2. Frequent watering to the lawn areas to insure against drying. This may be accomplished as above, by hand watering or portable sprinklers.

3.3 LANDSCAPE IRRIGATION SYSTEM

- A. Monitor and program the automatic controlling devices to provide optimum moisture levels in all planted areas.
1. Irrigation cycles shall be set to take place prior to sunrise (usually 4:00 - 5:00 am) unless otherwise instructed by the Owner, except during visits of grounds maintenance personnel; during such visits the irrigation system may be operated as desired by those personnel.
 2. If there is more than one irrigation controller, do not program to water during the same time period as over-draft of water meters will result. Set controllers so that one finishes watering cycle before next starts watering cycle. During periods of high rainfall, set controllers to "dry mode" until irrigation is needed. Do not switch controller to "off", as this will stop time clock.
 3. Complete sprinkler system servicing shall be performed as required to maintain sprinklers in correct operating condition, including all required labor. Operation of sprinklers shall be monitored on a bi-monthly basis to assure proper cover and operation.
 4. Adjust sprinklers to avoid damage to windows and buildings. Make repairs and alterations to the sprinkling system and water lines. All sprinklers repairs such as cleaning of heads or breaks caused by the Contractor shall be the Contractor's responsibility.
 5. Perform minor additions, subtractions and/or adjustments to irrigation equipment (i.e., addition of spray head or riser extension) as may be required to order to conform to the irrigation requirements herein specified. Such additions, subtractions and/or realignments to irrigation system equipment shall not materially reduce the extent or value of the irrigation system equipment, and shall be accomplished after securing approval of the Owner.
 6. Supplemental irrigation beyond that which can be provided by the irrigation system shall be provided by the grounds maintenance firm as required in order to assure optimum moisture levels.
 7. Sediment removal from project site as a result of bayou tide rising and receding by use of project stand pipes.

3.4 MAINTENANCE OF TURF AREAS

- A. Mowing lawn/grass areas shall be accomplished with sharp, properly adjusted mowers of the correct size for the various areas.
- B. Mowing frequency shall be as per the Landscape Maintenance Program. Blade heights shall be set according to the following schedule:
 - 2 Inches Initial Mowing
 - 2 Inches April - November
- C. In the event of a prolonged rainy period and a surge of leaf growth is anticipated, the mower height may be re-adjusted to prevent "scalping" or skinning of lawn on preceding cuts.
- D. Lawn shall be edged evenly at all walks, headers and other structures as per Landscape Maintenance Program.
- E. Until the establishment of the turf, the Contractor will be responsible for replacing soils that have eroded onto the paved areas. Residual soils on paving will be removed and if not mingled with objectionable materials, may be re-used in eroded areas.
- F. Immediately upon observing any lawn grass spreading into shrub or groundcover areas, the Contractor shall initiate a program of mechanical removal and maintain this program throughout the maintenance period.
- G. Any lawn grass appearing in paved areas shall receive an application of soil sterilant according to manufacturer's direction. The sterilant shall be approved and will not be detrimental structurally to paved areas.
- H. Special effort shall be given to the control of fire ants infesting the site. After control is accomplished, the ant mounds shall be lowered and tamped to the existing grade.
- I. Removal of debris from the site unrelated to horticultural maintenance (paper, bottles, cans, "Pirate" signs, etc.) shall be the responsibility of the maintenance Contractor and limited to areas designated.

3.5 MAINTENANCE OF TREES, SHRUBS, AND GROUNDCOVERS

- A. Contractor shall adjust and tighten as required all tree staking and guying. Removal as directed by Owner's Representative.
- B. Contractor shall deep water all new trees until there are definite signs the trees have established themselves and are pushing out new growth.
- C. Watering basins shall be removed by Contractor after the trees have established themselves or as directed by Owner's representative. Basins are normally removed one year from time of planting.

- D. Contractor shall be continuously alert for signs of insect presence or damage or the presence or damage from plant fungi. Upon locating such evidence, the Contractor shall report it to the Owner's representative and take action as directed.

3.6 MAINTENANCE FREQUENCY SCHEDULE

- A. Mowing, Edging, Trimming, Litter Cleanup, and Watering Monitoring: Four visits per month for 12 months.
- B. Topdress Fertilizer: Thirty days after seeding and/or sodding.
- C. Mulching, Weeding, Weed Control, and Guying Adjustment: As required each visit.
- D. Reseeding: As required upon notice.
- E. Tree and Plant Replacement: As required each visit.
- F. Trash and Debris Removal: Collect all trash and debris at each visit and dispose of off-site.

END OF SECTION 320190.13

SportMaster Sport Surfaces
PO Box 2277
2520 South Campbell Street
Sandusky, Ohio 44870
Toll Free 800-326-1994
Fax 877-825-9226
Website www.sportmaster.net
E-mail moreinfo@sportmaster.net

April 2020

Product Guide Specification

Specifier Notes: This product guide specification is written according to the Construction Specifications Institute (CSI) 3-Part Format, including *MasterFormat*, *SectionFormat*, and *PageFormat*, as described in *The Project Resource Manual—CSI Manual of Practice, Fifth Edition*.

This section must be carefully reviewed and edited by the Architect to meet the requirements of the project and local building code. Coordinate this section with other specification sections and the Drawings. Delete all “Specifier Notes” after editing this section.

Section numbers are from *MasterFormat 1995 Edition*, with section numbers from *MasterFormat 2004 Edition* in parentheses. Delete version not required.

SECTION 02790 (32 18 23.53)

CONCRETE PICKLEBALL COURT SURFACE COLOR COATING SYSTEM

Specifier Notes: This section covers SportMaster Sport Surfaces “SportMaster” concrete pickleball court surface color coating system. Consult SportMaster Sport Surfaces for assistance in editing this section for the specific application.

PART 1 GENERAL

1.1 SECTION INCLUDES

- A. Concrete pickleball court surface color coating system.

1.2 RELATED REQUIREMENTS

Specifier Notes: Edit the following list of related sections as required. Delete related sections not required. List other sections with work directly related to this section.

- A. Section 03300 (03 30 00) – Cast-in-Place Concrete.

- B. Section 03400 (03 40 00) – Precast Concrete.

1.3 REFERENCE STANDARDS

Specifier Notes: List reference standards mentioned in this section, complete with designations and titles. Delete reference standards not included in this edited section. This article does not require compliance with reference standards, but is merely a listing of those used.

- A. American Sports Builders Association (ASBA).
- B. United States of America Pickleball Association (USAPA) Rules of Pickleball.

1.4 SUBMITTALS

- A. Comply with Section 01330 (01 33 00) – Submittal Procedures.
- B. Product Data: Submit manufacturer's product data, including surface and crack preparation and application instructions.
- C. Samples: Submit manufacturer's color samples of color coating.
- D. Test Reports:
 - 1. Submit independent test results for solar reflectance index.
 - 2. Submit independent test results for 2000 Hour ASTM G154, accelerated weathering UV test, to demonstrate long-term durability and fade resistance.
 - 3. Submit independent test results for 2000 Hour, accelerated weathering ASTM G155 Xenon Arc test, to demonstrate long-term fade resistance and quality of pigment.
- E. Manufacturer's Certification: Submit manufacturer's certification that materials comply with specified requirements and are suitable for intended application.
- F. Manufacturer's Project References: Submit manufacturer's list of successfully completed concrete pickleball court surface color coating system projects, including project name, location, and date of application.
- G. Applicator's Project References: Submit applicator's list of successfully completed concrete pickleball court surface color coating system projects, including project name, location, type and quantity of color coating system applied, and date of application.
- H. Warranty Documentation: Submit manufacturer's standard warranty.
- I. Authorized Installer Certificate: Submit manufacturer's authorized installer certificate.

1.5 QUALITY ASSURANCE

- A. Manufacturer's Qualifications:
 - 1. Manufacturer regularly engaged, for past 5 years, in manufacture of concrete pickleball court surface color coating systems of similar type to that specified.

2. United States owned company.
3. Member: ASBA.

B. Applicator's Qualifications:

1. Applicator regularly engaged, for past 3 years, in application of pickleball court surface color coating systems of similar type to that specified.
2. Employ persons trained for application of pickleball court surface color coating systems.
3. Applicator must be authorized installer of the surfacing brand used.

1.6 DELIVERY, STORAGE, AND HANDLING

A. Delivery and Acceptance Requirements: Deliver materials to site in manufacturer's original, unopened containers and packaging, with labels clearly identifying product name and manufacturer.

B. Storage and Handling Requirements:

1. Store and handle materials in accordance with manufacturer's instructions.
2. Keep materials in manufacturer's original, unopened containers and packaging until application.
3. Store materials in clean, dry area indoors.
4. Store materials out of direct sunlight.
5. Keep materials from freezing.
6. Protect materials during storage, handling, and application to prevent contamination or damage.
7. Close containers when not in use.
8. Retain manufacturer batch codes on each container and application dates, for warranty purposes.

1.7 AMBIENT CONDITIONS

A. Do not apply concrete pickleball court surface color coating system when air or surface temperatures are below 50°F (10°C) during application or within 24 hours after application.

B. Do not apply concrete pickleball court surface color coating system when rain is expected during application or within 24 hours after application.

PART 2 PRODUCTS

2.1 MANUFACTURER

A. SportMaster Sport Surfaces, PO Box 2277, 2520 South Campbell Street, Sandusky, Ohio 44870. Toll Free 800-326-1994. Fax 877-825-9226. Website www.sportmaster.net. E-mail moreinfo@sportmaster.net.

All other brands must be pre-approved by the architect/owner, 7 days prior to the bid date. If submitting another brand, bidder must furnish copies of all submittal documents under section 1.4

2.2 MATERIALS

- A. Concrete Pickleball Court Surface Color Coating System: SportMaster Color Coating System.
- B. Crack Sealant: SportMaster “Crack Magic”.
 - 1. 100 percent acrylic emulsion elastomeric crack sealant.
 - 2. Seals cracks and expansion joints up to 1/2 inch wide in concrete pavement.
 - 3. Weight per Gallon at 77 Degrees F: 8.8 lbs., plus or minus 0.5 lbs.
 - 4. Non-Volatile Material: 61 percent, plus or minus 5 percent.
 - 5. Color: [Green] [Neutral] [Red].
- C. Crack Filler: SportMaster “Acrylic Crack Patch”.
 - 1. 100 percent acrylic emulsion trowel-grade crack filler.
 - 2. Fills cracks in concrete pavement up to 1 inch wide.
 - 3. Chemical Characteristics, by Weight, Minimum:
 - a. Acrylic Emulsion: 10.0 percent.
 - b. Hiding Pigment: 0.2 percent.
 - c. Mineral Inert Fillers: 78.0 percent.
 - d. Film Formers, Additives: 1.8 percent.
 - e. Water: 8.5 percent.
 - 4. Weight per Gallon at 77 Degrees F: 15.2 lbs., plus or minus 1.0 lbs.
 - 5. Non-Volatile Material: 80 percent, plus or minus 5 percent.
 - 6. Color: [Green] [Neutral] [Red] [Blue].
- D. Patch Binder: SportMaster “Acrylic Patch Binder”.
 - 1. 100 percent acrylic emulsion liquid binder.
 - 2. Mix on-site with sand and cement.
 - 3. Levels and repairs low spots and depressions up to 3/4 inch deep in concrete pavement.
 - 4. Fills Cracks in concrete up to 1” in width.
 - 5. Weight per Gallon at 77 Degrees F: 8.8 lbs., plus or minus 0.5 lbs.
- E. Adhesion Promoter: SportMaster “Acrylic Adhesion Promoter”.
 - 1. Acrylic emulsion primer.
 - 2. Primes concrete surface and promotes adhesion of color coating system materials.
 - 3. Weight per Gallon at 77 Degrees F: 8.7 lbs., plus or minus 0.5 lbs.
- F. Filler Course: SportMaster “Acrylic Resurfacer”.
 - 1. 100 percent acrylic emulsion resurfacer.
 - 2. Mix on-site with silica sand.
 - 3. Apply to adhesion promoter or previously colored acrylic surfaces in preparation of color coating system.
 - 4. Chemical Characteristics, by Weight, Minimum:
 - a. Acrylic Emulsion: 44.0 percent.
 - b. Hiding Pigment: 2.0 percent.
 - c. Mineral Inert Fillers: 5.0 percent.
 - d. Film Formers, Additives: 0.2 percent.
 - e. Water: 45.0 percent.
 - 5. Weight per Gallon at 77 Degrees F: 8.5 lbs., plus or minus 0.5 lbs.
 - 6. Non-Volatile Material: 27.5 percent, plus or minus 5.0 percent.
 - 7. Color: [Black] or [Neutral].

- G. Color Coating: SportMaster "ColorPlus System".
1. 100 percent acrylic emulsion coating.
 2. Mix on-site with silica sand and water.
 3. Color coats pickleball, tennis, and multipurpose courts.
 4. Weight per Gallon at 77 Degrees F: 9.2 lbs., plus or minus 0.5 lbs.

Specifier Notes: Specify color of color coating. The following colors can contribute to LEED credits for SS Credit 7.1: Heat Island Effect – Non-Roof: Dove Gray, Ice Blue, Light Green, Red, Sandstone, Orange and Yellow. Also note * are premium cost colors.

5. Color: [Beige] [Blue] [Brown] [Dark Green] [Dove Gray] [Forest Green] [Gray] [Ice Blue] [Light Blue] [Light Green] [Maroon] [Red] [Sandstone] [*Tournament Purple] [*Orange] [Yellow] [*Brite Red] [Black]

- H. Line Markings Primer: SportMaster "Stripe-Rite".
1. 100 percent acrylic emulsion primer, clear drying.
 2. Primes line markings and prevents bleed-under for sharp lines.
 3. Chemical Characteristics, by Weight, Nominal:
 - a. Acrylic Emulsion: 38.0 percent.
 - b. Hiding Pigment: 0.0 percent.
 - c. Mineral Inert Fillers: 7.0 percent.
 - d. Film Formers, Additives: 1.5 percent.
 - e. Water: 50.0 percent.
 4. Weight per Gallon at 77 Degrees F: 8.9 lbs., plus or minus 0.5 lbs.
 5. Non-Volatile Material: 29 percent, plus or minus 5 percent.

- I. Line Paint: SportMaster "Textured Line Paint".
1. Pigmented, 100 percent acrylic emulsion line paint.
 2. Line marking on concrete pickleball courts.
 3. Chemical Characteristics, by Weight, Nominal:
 - a. Acrylic Emulsion: 25.89 percent.
 - b. Pigment: 14.90 percent.
 - c. Mineral Inert Fillers: 13.12 percent.
 - d. Additives: 4.73 percent.
 - e. Water: 41.36 percent.
 4. Weight per Gallon at 77 Degrees F: 10.65 lbs., plus or minus 0.75 lbs.
 5. Non-Volatile Material: 45.17 percent, plus or minus 5 percent.

Specifier Notes: Specify color of line paint.

6. Color: White.

PART 3 EXECUTION

3.1 EXAMINATION

- A. Examine concrete pickleball court surfaces to receive color coating system.

- B. Verify:
 - 1. Suitable vapor barrier beneath concrete slab.
 - 2. Perimeter drainage to prevent moisture accumulation beneath concrete surface.
 - 3. Curing compounds have not been used on concrete surface.
 - 4. Concrete pickleball courts meet ASBA requirements.
- C. Notify Architect of conditions that would adversely affect application or subsequent use.
- D. Do not begin surface preparation or application until unacceptable conditions are corrected.

3.2 SURFACE PREPARATION

- A. Protection of In-Place Conditions: Protect adjacent surfaces and landscaping from contact with concrete pickleball court surface color coating system.
- B. Prepare surfaces in accordance with manufacturer's instructions.
- C. New Concrete:
 - 1. Cure new concrete surfaces a minimum of 28 days before application of concrete pickleball court surface color coating system.
 - 2. Provide medium broom finish or similar roughened texture.
 - 3. Do not steel trowel finish.
 - 4. Acid etch surface per manufacturers specifications, then rinse thoroughly.
- D. Existing Concrete:
 - 1. Sandblast, shotblast, or scarify smooth concrete surfaces to roughened texture similar to medium broom finish. If shot blasting, a shot blast profile of CSP3 or CSP4 is recommended.
 - 2. If existing concrete is uncoated, acid etch with phosphoric or muriatic acid and rinse thoroughly prior to application of color coating system
- E. Remove dirt, dust, debris, oil, grease, sealers, curing compounds, vegetation, loose coatings, loose materials, and other surface contaminants which could adversely affect application of concrete pickleball court surface color coating system. Pressure wash entire surface.
- F. Repair cracks, depressions, and surface defects in accordance with manufacturer's instructions before application of color coating.
- G. Repair spalled areas and level depressions 1/8 inch and deeper with patch binder in accordance with manufacturer's instructions.
- H. Apply adhesion promoter over entire concrete surface in accordance with manufacturer's instructions.
- I. Apply 1 coat of filler course to provide smooth underlayment for application of color coating.
- J. Ensure surface repairs are flush and smooth to adjoining surfaces.

3.3 APPLICATION

- A. Apply concrete pickleball court surface color coating system in accordance with manufacturer's instructions at locations indicated on the Drawings.
- B. Mix materials in accordance with manufacturer's instructions.
- C. Apply Filler Course and Color Coating with a 50-60 durometer, soft rubber squeegee.
- D. Filler Course:
 - 1. Apply 1 coat on new concrete or existing acrylic surfaces with minimal repairs.
 - 2. Apply 2 coats on existing acrylic surfaces with extensive cracks or low spot repair.
- E. Apply a minimum of 2 coats of color coating to prepared surfaces in accordance with manufacturer's instructions.
- F. Allow material drying times in accordance with manufacturer's instructions before applying other materials or opening completed surface to foot traffic.

3.4 LINE MARKINGS

- A. Lay out pickleball court line markings in accordance with USAPA Rules of Pickleball.
- B. Apply line markings primer, after masking tape has been laid, to seal voids between masking tape and pickleball court surface to prevent bleed-under when line paint is applied.
- C. Apply a minimum of 1 coat of line paint in accordance with manufacturer's instructions.

3.5 PROTECTION

- A. Allow a minimum of 24 hours curing time before opening pickleball courts for play.
- B. Protect applied concrete pickleball court surface color coating system to ensure that, except for normal weathering, coating system will be without damage or deterioration at time of Substantial Completion.

END OF SECTION